

Toward a Sustainable Cement Industry

How INNOVATION CAN HELP THE CEMENT INDUSTRY MOVE TOWARD MORE SUSTAINABLE PRACTICES

March 2002



An Independent Study Commissioned by

• • • • • • • • • •

Toward a Sustainable Cement Industry

***Substudy 7: How Innovation Can Help the
Cement Industry Move Toward More
Sustainable Practices***

March 2002

by
Marylynn Placet and Kim Fowler

with contributions from
**Kathryn Baker, Jill Engel-Cox, Charles Lewinsohn, Battelle
Etienne Simon, FCB.Ciment**

• • • • • • • • • •

An Independent Study Commissioned by:

Battelle
The Business of Innovation.



World Business Council for
Sustainable Development

World Business Council for Sustainable Development

This substudy is one of 13 research investigations conducted as part of a larger project entitled, "Toward a Sustainable Cement Industry". The project was commissioned by the World Business Council for Sustainable Development as one of a series of member-sponsored projects aimed at converting sustainable development concepts into action. The report represents the independent research efforts of Battelle Memorial Institute and their subcontractors to identify critical issues for the cement industry today, and pathways forward toward a more sustainable future. While there has been considerable interactive effort and exchange of ideas with many organizations within and outside the cement industry during this project, the opinions and views expressed here are those of Battelle and its subcontractors.

Battelle

Battelle endeavors to produce work of the highest quality, consistent with our contract commitments. However, because of the research nature of this work, the recipients of this report shall undertake the sole responsibility for the consequence of their use or misuse of, or inability to use, any information, data or recommendation contained in this report and understand that Battelle makes no warranty or guarantee, express or implied, including without limitation warranties of fitness for a particular purpose or merchantability, for the contents of this report. Battelle does not engage in research for advertising, sales promotion, or endorsement of our clients' interests including raising investment capital or recommending investments decisions, or other publicity purposes, or for any use in litigation.

The recommendations and actions toward sustainable development contained herein are based on the results of research regarding the status and future opportunities for the cement industry as a whole. Battelle has consulted with a number of organizations and individuals within the cement industry to enhance the applicability of the results. Nothing in the recommendations or their potential supportive actions is intended to promote or lead to reduced competition within the industry.

Foreword

Many companies around the globe are re-examining their business operations and relationships in a fundamental way. They are exploring the concept of *Sustainable Development*, seeking to integrate their pursuit of profitable growth with the assurance of environmental protection and quality of life for present and future generations. Based on this new perspective, some companies are beginning to make significant changes in their policies, commitments and business strategies.

The study, of which this substudy is a part, represents an effort by ten major cement companies to explore how the cement industry as a whole can evolve over time to better meet the need for global sustainable development while enhancing shareholder value. The study findings include a variety of recommendations for the industry and its stakeholders to improve the sustainability of cement production. Undertaking this type of open, self-critical effort carries risks. The participating companies believe that an independent assessment of the cement industry's current status and future opportunities will yield long-term benefits that justify the risks. The intent of the study is to share information that will help any cement company – regardless of its size, location, or current state of progress – to work constructively toward a sustainable future. The pursuit of a more sustainable cement industry requires that a number of technical, managerial, and operational issues be examined in depth. This substudy, one of 13 conducted as a part of the project, provides the basis for assessing the current status or performance and identifies areas for progress toward sustainability on a specific topic. The project report entitled ***Toward a Sustainable Cement Industry*** may be found on the project website: <http://www.wbcdcement.org>.

Study Groundrules

This report was developed as part of a study managed by Battelle, and funded primarily by a group of ten cement companies designated for this collaboration as the Working Group Cement (WGC). By choice, the study boundaries were limited to activities primarily associated with cement production. Downstream activities, such as cement distribution, concrete production, and concrete products, were addressed only in a limited way. Battelle conducted this study as an independent research effort, drawing upon the knowledge and expertise of a large number of organizations and individuals both inside and outside the cement industry. The cement industry provided a large number of case studies to share practical experience. Battelle accepted the information in these case studies and in public information sources used.

The WGC companies provided supporting information and advice to assure that the report would be credible with industry audiences. To assure objectivity, a number of additional steps were taken to obtain external input and feedback.

- A series of six dialogues was held with stakeholder groups around the world (see Section 1.5).
- The World Business Council for Sustainable Development participated in all meetings and monitored all communications between Battelle and the WGC.
- An Assurance Group, consisting of distinguished independent experts, reviewed both the quality and objectivity of the study findings.
- External experts reviewed advanced drafts of technical substudy reports.

The geographic scope of the study was global, and the future time horizon considered was 20 years. Regional and local implementation of the study recommendations will need to be tailored to the differing states of socioeconomic and technological development.

Acknowledgements

The authors wish to acknowledge the efforts of many people – too numerous to name – from the cement company sponsors who spent considerable time and effort to provide information about technological, product and management innovations, and to provide reviews of draft materials. We also greatly appreciate technical reviews by Professor Fred Glasser of Aberdeen University, U.K. In addition, we would like to acknowledge the valuable contributions of Appendix B.2 by M. Etienne Simon of FCB.Ciment and parts of Appendix A reviewed by Atle Lygren of EMC.

List of Acronyms

A&E	Architectural and engineering
CKD	Cement kiln dust
EMC	Energetically Modified Cement
ETA	European Technical Approval
OPC	Ordinary Portland cement
SCR	Selective catalytic reduction
SINTEF	Foundation for Scientific and Industry Research
SNCR	Selective non-catalytic reduction
SRE	Stabilized Rammed Earth
SD	Sustainable Development
WGC	Working Group Cement (ten core cement company sponsors)

Glossary

Aggregate Gravel, sand, crushed stone, and possibly other materials used in making concrete.

Alternative Fuels Energy containing wastes used to substitute for conventional thermal energy sources.

Alternative Fuels and Raw Materials (AFR) Inputs to cement production derived from industrial, municipal, and agricultural waste streams.

Binder Cohesive agent which could include cement, blended cements, and fly ash.

Biomass Plant materials and animal waste used as a source of fuel.

Blast furnace slag A processed waste product of iron production in blast furnaces that is usable as a pozzolan.

Blended cement[†] Cement with a fixed percentage of pozzolans (for example, supplements such as slag and fly ash produced by the steel and electric power industries, respectively) replacing the Portland cement clinker portion of the cement mix. Blended cement is usually understood as cement that is blended by a cement manufacturer rather than a ready-mix supplier (also referred to as composite cement).

By-Product Secondary product of an industrial process.

Cement Within the cement industry, and especially the technical domain, this term is often understood as Ordinary Portland Cement.

Clinker Decarbonized, sintered, and rapidly-cooled limestone. Clinker is an intermediate product in cement manufacturing.

Concrete A material produced by mixing binder, water, and aggregate. The fluid mass undergoes hydration to produce concrete. (Average cement content in concrete is about 15%).

Fly ash By-product with binding properties typically produced as a residue from coal-fired power plants.

Fossil fuel A general term for combustible geological deposits of carbon in reduced (organic) form and of biological origin, including coal, oil, natural gas, and oil shale.

Greenhouse gases Gases in the earth's lower atmosphere that may contribute to global warming, including the major component CO₂.

^{*} The International Council for Local Environmental Initiatives (ICLEI, 2001, Cement Glossary, <http://www.iclei.org/us/cement/glossary.html>)

[†] The International Council for Local Environmental Initiatives (ICLEI), 2001, <http://www.iclei.org/about.htm>.

Industrial ecology Framework for improvement in the efficiency of industrial systems by imitating aspects of natural ecosystems, including the cyclical transformation of wastes to input materials.

Kiln Large industrial oven for producing clinker used in manufacture of cement.

Ordinary Portland Cement (OPC) Cement that consists of approximately 95 percent ground clinker and 5 percent gypsum.

Pozzolan A mineral admixture that acts as a supplement to standard Portland cement hydration products to create additional binder in a concrete mix.[‡]

Stakeholder Value Value directly relating to the stakeholders' perceptions.

Stakeholder A person or group that has an investment, share, or interest in something, as a business or industry.

Sustainable development Ability to continually meet the needs of the present without compromising the ability of future generations to meet their own needs.

Virgin fossil fuel A hydrocarbon deposit consisting of the remains of animal or vegetable life from past geologic ages and that is now in a combustible form suitable for use as fuel; for example, oil, coal, or natural gas.

Waste A by-product material having no or minimal economic value derived from a process or activity.

[‡] The International Council for Local Environmental Initiatives (ICLEI, 2001, Cement Glossary, <http://www.iclei.org/us/cement/glossary.html>)

Executive Summary

This substudy was tasked with investigating “how innovation can help the cement industry move toward more sustainable practices.” It describes the current status of innovation in the industry, including the drivers, barriers and enablers of innovation, as well as examples of how cement companies have introduced more sustainable practices over the past few decades. It also discusses the need for more radical innovations in the future to address the key issues associated with sustainability in this industry, including **(1) resource productivity, (2) climate protection, (3) emission reduction, (4) ecological stewardship, (5) employee well being, (6) community well being, (7) regional development, and (8) shareholder value creation.** Innovation is considered by some sustainability leaders to be a key enabler that helps industry make significant steps toward sustainability.¹

Over the past few decades, various types of innovation have helped the cement industry improve its environmental profile and contribution to society. These innovations were motivated by pressure for cost reduction, by the emergence of public and government concern over environmental degradation, and sometimes by the scarcity of land resources or an interest in improving the company’s image and helping society. As a result, some cement companies have introduced innovations such as novel quarrying methods, energy efficiency improvements, environmental controls, and new cement products that incorporate waste products and reduce natural resource use.

Cement companies interested in becoming more sustainable in the future can follow a number of different pathways. Each company will need to choose an individualized approach to sustainability that fits well within its organizational culture, company-specific situation, and business strategy. This report describes some of the possible pathways, and provides examples of emerging technologies or concepts to help illustrate those pathways. **The report does not attempt to document all sustainable cement technologies, practices and pathways; nor does it make specific recommendations about which process, product or business strategy innovations individual cement companies should pursue.** Cement companies themselves are in the best position to conduct (or support) the research needed to invent, test and evaluate potential sustainable technologies, and many emerging innovations are (and should be) proprietary to those companies that have invented them. The ideas in this report, which were developed through interviews and a review of the open literature, are presented **to stimulate thinking and provide a general idea of possible directions toward sustainability.** When choosing which pathways to pursue, a cement company should

- Ensure many sustainability-focused options for the future are being considered
- Examine the options from a holistic environmental and societal perspective (e.g., using lifecycle analysis and tools to estimate the value to society of various innovations)
- Consider a wide range of stakeholder perspectives
- Consider the financial risks and benefits of various alternative approaches, including the risks and benefits of not innovating

Many process, product and management innovations can contribute to future sustainability. Examples of sustainable **process** changes include:

- Enhanced methods for using waste and biomass fuels in kilns, including better ways to monitor air pollutant emissions from kilns using such fuels
- New kiln concepts, such as advanced fluidized bed combustion, lower temperature processes, or use of microwaves or plasma in the cement-making process
- Co-production of cement and electricity, e.g., innovative ways to burn coal to produce electricity and turn coal by-products (i.e., ash) into cement
- Use of low-carbon, hydrogen-rich fuels for CO₂ emission reduction

- Carbon capture and sequestration
- Lower-cost ways to reduce air pollution to the level of near-zero emissions

Product innovations aimed at sustainability include:

- Use of renewable and waste materials, such as fly ash, rice husk ash, and waste concrete components (e.g., by including superplasticizers)
- New pozzolanic additives (e.g., kaolin-montmorillonite-illite clays and palm oil fuel ash)
- Cement with increased reactivity or lower calcium content, such as Energetically Modified Cement (EMC) and cement with higher belite content
- Developing and marketing concretes with increase durability and/or strength (e.g., reactive powder concretes or other ultra-high-performance formulations), which potentially decrease the need to replace older structures, creating less waste for disposal and lower fuel use and emissions associated with clinker production
- Testing and deploying methods to increase the longevity of existing concrete structures, e.g., using special coatings (such as those including polymer or magnesium- phosphate cements), or methods such as realkalization or osmosis and electrolysis.
- Creating cement-like products produced through new processes (e.g., geopolymers, polymer concrete made from recycled PET resin, chemically bonded ceramics made from magnesium oxide and phosphate powders, cement made through polyvinyl alcohol polymerization)
- Developing inexpensive building products and techniques that use cement, such as bamboo-cement structures; cement blocks or boards that combine cement with locally-available, low-cost materials; and the safe use of lower quality cements or aggregates in appropriate applications

Examples of **management/business concept** innovations that could foster sustainability include:

- Developing new product delivery mechanisms in developing countries to fulfill the needs in poorer areas
- Selling structural guarantees for innovative concretes with improved performance
- Combining cement production with an energy and/or CO₂ management business
- Expanding the scope of the cement company to include waste management and resource extraction businesses

A number of impediments hold the cement industry back from making radical changes. Cement production is very capital intensive, and the long time period required to recoup investments leads to a conservative attitude toward change and a desire to continue to pursue markets for traditional (Portland) cement. In addition, customers are wary of changes in the cement they trust and are accustomed to using. Standards and building codes have been developed over the years to prevent untested innovations from adversely affecting safety of building and other structures, but they can also provide an impediment to introducing innovations. A strong interest in increasing sustainability can (and has, in some cases) overcome such impediments. As consumers of cement and concrete become more aware of sustainability issues, market forces may provide additional pressures for change. For instance, specifications may increasingly call for blended cement products that have been approved under new standards.

Cement companies interested in pursuing sustainability-oriented change are challenged to find the right kinds of sustainable products, processes and business concepts that also maintain or increase company profitability. Cement companies that are successful in this pursuit could lower costs; increase sales volumes or margins; reduce the threat of competition from other companies, other building materials, or disruptive innovations from outside the industry;

provide higher returns to shareholders; and command higher share prices than their counterparts that do not innovate.

Cement companies can foster innovation in their organizations by:

- Soliciting innovation ideas from employees
- Encouraging team thinking
- Rewarding and recognizing staff initiative toward sustainability-oriented innovation
- Conducting competitive intelligence and knowledge management to identify and distribute information on innovations from outside the company
- Managing the innovation “stream” by introducing systems to gather and store novel ideas, selecting promising ideas for experimentation, managing the innovation development process for serious ideas (possibly including creating ad-hoc separate organizations to further develop them), and diffusing innovation once it has been created
- Forming partnerships with other organizations (universities, other companies, suppliers, etc.) to promote pre-competitive R&D focused on sustainability

The research conducted for this report led to the recommendations below, which are grouped into two categories, (1) those involving more widespread application of past innovations, and (2) those related to developing new products, processes and management innovations.

1. Foster more widespread application of past innovations and best practices:

- Continuously improve existing plants and quarries by identifying and using best practices during siting, planning, and operation to assess, monitor and manage development and reduce impacts
- Design new plants to incorporate state-of-the-art technology such that they have a low level of public disturbance, decreased impact on natural systems, and near-zero emissions
- Find productive, environmentally sound, and socially acceptable uses for depleted quarries and retired plants
- Encourage increased use of blended/composite cement to reduce the amount of limestone calcined and the level of CO₂ emissions

2. Increase emphasis on developing product, process and management innovations that make stepwise improvements in environmental and societal aspects of cement production and use, while maintaining the viability of the cement industry.

- Increase cement company role in cement process design by helping equipment suppliers set an R&D agenda for process change oriented toward sustainable development (SD) and by providing financial support for SD-oriented process R&D, including work at universities and by other parties outside cement companies
- Develop (or support development of) cement-based products specifically aimed at environmental or social improvements by including environmental and societal benefit criteria in the R&D project selection process
- Encourage creative SD thinking among employees by providing support, incentives and rewards for SD innovation, using knowledge management systems and cross-company meetings to share innovative ideas, and effectively managing the innovation “stream”
- Conduct or support research to characterize the risks and benefits of innovations, such as use of alternative fuels and raw materials
- Create a *Sustainable Development Institute of Cement and Concrete* to promote worldwide progress toward sustainable production and use of cement and concrete

Table of Contents

1. Introduction: Why Innovate?.....	1
1.1. Why Should the Cement Industry Innovate toward Sustainable Practices?.....	1
1.2. How did this Study Approach the Topic of Innovation in the Cement Industry?	5
2. Current Status of Innovation in the Cement Industry: Where does Sustainability Begin?	8
2.1. Drivers of Innovation	8
2.2. Impediments to Innovation	9
2.3. Enablers of Innovation	11
2.4. Current Status of Sustainability-Oriented Innovation in the Cement Industry.....	11
3. Innovations Toward a More Sustainable Cement Industry: What are Some Pathways on the Journey?	19
3.1. Process Pathways Toward Sustainability	20
3.2. Product Pathways Toward Sustainability	24
3.3. Management Innovations that Could Foster Sustainability	28
4. Creating Sustainability-Focused Innovation: How Can a Company Get There?	31
5. Recommendations	34
6. References	36
Appendix A Innovation Examples – Short Case Studies.....	A-1
Appendix B: Innovation Examples – Detailed Case Studies	B-1
Appendix B.1 Crosscutting Case Lampang Plant: A New Cement Plant of Siam Cement Industry	B-2
Appendix B.2 Focused Case Study: The Horomill Grinding Technology	B-8

List of Tables

Table 2-1. Innovations that Have Been Implemented in the Cement Industry.....	12
Table 3-1. Potential Future Innovation Pathways.....	19
Table A.1. Process Innovations	A-2
Table A.2. Product Innovations.....	A-7
Table A.3. Management Innovations	A-16
Table B.2.1 Horomill Plant Installations	B-20

1. Introduction: Why Innovate?

Portland cement - the type that dominates in most of today's markets - has been produced in basically the same way for over one hundred years. Although the industry gradually adopts new equipment to reduce costs, improve energy efficiency, and lower environmental impacts, most cement plant changes since the advent of the rotary kiln have been incremental. But this has not prevented the cement industry from being successful. Cement plays a critical role in the world's economy, and global sales continue to increase as the world's population and economy grow. The industry remains profitable. Some people argue that the industry's success is attributable to the fact that the product is well tested, reliable, and unchanging, and that it can be produced at low cost.

Then why change? This sub-study was tasked with investigating "how innovation can help the cement industry move toward more sustainable practices." The concept of innovation has been discussed in the literature for over sixty years.^{2,3} In this study, the types of innovation investigated are improvements related to reducing the environmental effects and to increasing the positive social impacts of both cement products and production processes. It also addresses management innovations that can support the goals of sustainability. So, within the context of this study, the question "Why innovate?" begins with a discussion of why the industry might be interested in becoming more "sustainable."

1.1. *Why Should the Cement Industry Innovate toward Sustainable Practices?*

Introducing innovative products, processes and business practices can help move the cement industry toward increased sustainability. The sustainability issues driving innovation in the cement industry include:

1. **Resource Productivity.** The concept of sustainability is derived from a belief that the earth has a finite capacity to supply non-renewable resources, such as fossil fuels. Proponents of sustainability contend that resource consumption in all industries should decrease by a minimum of a factor of four⁴ or ten.⁵ The cement production process calcines limestone at high temperatures and consumes about 2% of the global primary energy consumption and almost 5% of total industrial energy consumption (International Energy Agency). As a rule of thumb, 1.5-1.6 tons of dry raw materials (limestone plus some other materials) are required to produce one ton of clinker.⁶ Limestone resources within the earth's crust far exceed that needed to supply any foreseeable demand for cement, but limestone quarrying has some negative effects (see item 4 below). Sustainability in this industry would be increased by the invention of innovative ways reduce the amount of natural resources used per tonne of cement. Radically different products and processes would be required for this industry to reduce resource use by a factor of four or ten.

What is Innovation?

More than 60 years ago, economist Joseph Schumpeter described innovation as a process, starting from a kernel of an idea and continuing through all the steps needed to reach a marketable product that changes the economy. The concept of innovation has significantly changed since this time. We now distinguish levels of innovation (e.g., incremental to radical) and no longer restrict the term to only the creation of new products that change the economy. Innovation is also no longer restricted to product innovation, although this is still the primary focus of much of the literature. Finally, innovation is not necessarily restricted to the process of creating something new from beginning to end but includes the capacity to quickly adopt externally created innovations that may be of benefit to the organization.

For instance, the cement industry is in a good position to help communities reduce the growing volume of many types of waste produced by human activities, while helping with resource conservation. Since the industrial revolution in the early 19th century, human activities over the globe have produced several billion tons of waste. Certain types of waste can fuel cement kilns, thus reducing the volume of waste sent to landfills or incinerated (and also reducing fossil fuel use, as discussed above). In the case of wastes containing harmful organic substances, the high temperatures in the kilns can decompose these organic wastes and transform or incorporate them into the product in a harmless form. Innovations can help improve the use of wastes in cement kilns. Innovations in monitoring or other ways to better understand the impacts of waste use in cement can help create public acceptance and create a more favorable attitude toward use of these fuels.

Construction activities also produce waste. When aging infrastructure is demolished as needs change or as the concrete reaches the end of its useful life, demolition waste is created. Innovations that can make productive use of this type of demolition waste are also needed.

2. **Climate protection.** The combustion of fuels (especially high-carbon fuels such as coal and petroleum coke), combined with the production of CO₂ from the process itself (i.e., the calcining of limestone to produce clinker, then cement), result in cement industry CO₂ emissions that comprise a meaningful portion – about 3% – of total global emissions of CO₂ (see [Substudy 8: Climate Change](#)). This is one of the most serious sustainability issues the cement industry faces. Lowering the use of fossil fuels and supplementing limestone-based cement with other cementitious materials are part of the solution. Innovation may help the industry lower or manage CO₂ emissions in novel ways.
3. **Emission Reduction.** Some scientists have expressed concern that pollution levels may increase to a level beyond the earth's maximum carrying capacity. Pollution above a certain level might saturate and actually erode the natural mechanisms of pollution absorption.⁷ Others are concerned about the mobilization of metals and other substances caused by extraction and movement of material by industrial operations.⁸ Although the contribution of emissions from the production of cement to the total emission inventory is quite low in the industrial world,⁹ the process does emit dust, sulfur dioxide, nitrogen oxides, and other pollutants. Cement companies have initiated many changes that have improved the pollution profile of many cement plants. Innovations may result in even lower levels of environmental impact, which may be important in the future as more and more human activities place burdens on the carrying capacity of the natural environment. Many of these innovations require additional inputs of energy and may shift the point at which additional pollutants are generated to other parts of the energy chain. Any audit should therefore ensure that changes result in an overall decrease in pollution.
4. **Ecological stewardship.** Quarries disturb land, can mobilize metals and other materials into the environment that were previously undisturbed, and potentially affect natural ecosystems. Concerned about these issues, many cement companies have already taken steps to improve quarrying and quarry restoration techniques. The more widespread use of progressive and innovative methods of quarrying will help move the cement industry toward a sustainable future. The cement industry has also played another role in ecological stewardship: cement-based products have been used to solve environmental problems, such as treating contaminated soils and providing safe ways to isolate wastes from the

⁸ For example, artificial releases of lead into the environment are almost twelve times greater than natural releases, and as industrial activity continues to increase, this may begin to create an overload that natural systems cannot handle.⁸

environment (see Section 2). Cement companies interested in sustainability could seek innovative ways to solve a wider range of environmental problems using cement-based products.

5. **Employee Well Being.** Sustainability also involves improving conditions and satisfaction of workers. Innovative management techniques and programs for workers can play an important role in moving cement companies toward a sustainable future. For example, companies can initiate training or career enhancing activities (such as rotation of jobs), and provide a comfortable and supportive work environment.
6. **Community Well Being.** Cement production can have both positive and negative effects on communities. On the positive side, the industry provides jobs and can also provide services to the communities in which it operates (see Appendix B.1 for some examples). On the negative side, cement production can create noise, disturb neighbors, create dust and make other nuisances. Many cement companies have taken steps to reduce these impacts, and have also begun programs to work with communities through dialogue to understand and better address concerns and needs. Improved technologies to reduce public disturbance (noise, dust, traffic congestion associated with trucks, etc.) can help the cement industry improve community well being. In addition, the cement industry can continue to innovate with respect to how it deals with people in communities surrounding its plants and to better understand and assist communities meet everyday needs such as water, food, and education.
7. **Regional development.** The availability of cement offers opportunities for construction of bridges, roads, houses, schools, water and waste management systems, industrial and commercial enterprises, etc. – the basic infrastructure of modern society. Growth in developing countries is expected to far outstrip growth in the developed world, and cement is the “foundation” for that development. Developing countries could meet their infrastructure needs in a more sustainable and affordable way if the cement industry creates product innovations – for instance, low-cost construction materials that use cement, or specialized products that make infrastructure development more affordable and allow more of the earth’s poorer residents to have access to basic infrastructure.
8. **Create shareholder value.** Some research supports the supposition that innovative companies are more successful financially than those that do not innovate. For instance, a survey of Wall Street analysts showed that capital markets place value on a company’s ability to innovate; analysts believe innovative companies command a higher share price than their less innovative counterparts.^{**10} But even companies or industries that consistently innovate can be threatened by “disruptive” innovations from outside the mainstream industry (see box on following page). It is unlikely that disruptive technologies will seriously threaten the dynamics of the global cement industry in the short term. But disruptive innovations aimed at increasing the sustainability of cement (e.g., lowering its CO₂ emissions) may gain market share if the market for ‘sustainable’ cement grows. Cement companies would lessen this threat by developing sustainability-oriented innovations (and even disruptive innovations) inside their own companies. They could also lower the threat by scanning for sustainability-focused disruptive technologies developed outside cement companies (at universities or by independent companies) and licensing or investing in those that could be profitable. (Such a strategy would have a more positive impact on sustainability than an approach focused on eliminating the threat of these disruptive

^{**}In addition, *Fortune* magazine ranks the “most admired” companies both globally and in the United States and includes innovation as one of the criteria in the ranking. Innovation rankings were directly correlated to rankings for shareholder return across most industries.

technologies altogether.) Cement companies that are successful at introducing new sustainable processes, products or business concepts could lower costs, increase sales volume or margin, reduce the threat of competition from current or future competitors, provide higher returns to shareholders, and command higher share prices than their counterparts that do not innovate.

Not all sustainability-oriented innovation will lead to business success. Cement companies that are committed to sustainability are challenged **to find the right kinds of sustainable products and processes that also maintain or increase company profitability**. Each company must decide on its own sustainability strategy that is compatible and interwoven with its competitive strategy. Only the future will tell which innovations will prove most effective and profitable. And only the future will tell if environmental and social issues move along a pathway that will make sustainability a global imperative. More and more, business leaders have begun to transform the vague concept of sustainability into a more practical, actionable set

The Disruptive Minimill Steel Technology

The “mini-mill” introduced in the steel industry (a “heavy” industry with some similar characteristics to the cement industry) provides an example of how a new process that produced a product, initially considered inferior to normal steel, eventually took over 40% of the market. Introduced in 1975, the “minimill” process recycles scrap steel, drastically reducing virgin material and energy use. It was first used to convert scrap steel into reinforcement bars (a low-margin product), which are used in concrete construction. The mainstream steel industry, focused on increasing its revenues from high-value products, was not concerned about this new entrant capturing a low-margin segment of the market. Mainstream steel industry profit margins actually increased when mini-mills were first introduced. Over time, the mini-mill technology improved, and the quality of its products increased to the point where it could compete for high-value products. Now North America’s mini-mills are the most efficient, lowest-cost steel makers in the world, and these mills are much less resource and energy intensive than mills that process virgin iron ore. Could there be a “mini-mill” analog in the future of the cement industry? Could a new process be invented outside the mainstream cement industry that could produce a more sustainable product that will eventually successfully compete with Portland cement made in traditional kilns? Or will the mainstream cement industry develop such innovations themselves?

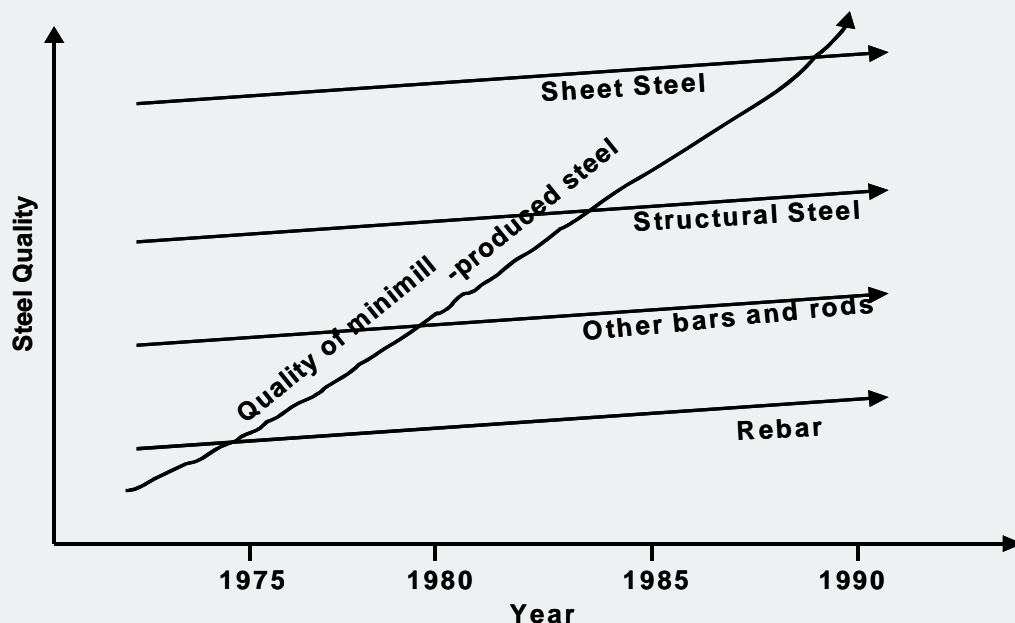

Reference: Christensen¹¹

of principles (see box). In a recent report on sustainability, Hardin Tibbs of the Global Business Network wrote,

“Organizations intending to take action on the issue of sustainability face decision-making paradoxes [that] preclude a clear logical rationale for taking action. Sustainability therefore confronts organizations with the need to determine what they think *should* be done, rather than only what can be analytically justified. Assessing the seriousness of unsustainability requires organizational decision makers to make a judgment, based on their beliefs and values and a holistic assessment of risk. Such an uncomfortable but unavoidable position will involve organizations in the wider social process of exploring new values.”¹²

Excerpts from Sustainability Through the Market^{*}

International non-governmental organizations ha[ve] calculated that extrapolation of the consumption rates in developed countries to the rest of the world would require the equivalent of three Earths. Since we could not condemn the developing countries to live in poverty so those in the developed economies could maintain their lifestyles, and we had not found two more Earths, the option that was being promoted was limiting choice and access to products. ... As business leaders, we viewed it as destroying the very premise for businesses' existence—to create goods and services that improve quality of life. ... We challenged ourselves to create a more inspirational vision... **Companies have the opportunity to improve people's lives through what they do and how they do it, and in doing so, build their business.**

Key 1: Innovate – Both technological and social innovation can do much to improve quality of life and address the depletion of resources and the build- up of pollution around the world. Markets foster innovation by encouraging experimentation and rewarding those ideas that meet people's needs and aspirations most efficiently. ... [I]nnovation can enable our global economy to depend more on human ingenuity than on the exploitation of nature. **If we are to become more sustainable in the way we live our lives, we must find new ways to do old things, as well as new ways to do new things.**

*Reference: Holliday and Pepper¹

Note: Chad Holliday is Chairman and CEO of Dupont; John Pepper is Chairman of Procter & Gamble. Sustainability through the Market includes six additional "keys to success" including: practice eco-efficiency, move from stakeholder dialogues to partnerships for progress, provide and inform consumer choice, improve market framework conditions, establish the worth of the earth, and make the market work for everyone.

1.2. How did this Study Approach the Topic of Innovation in the Cement Industry?

This report documents examples of innovations that have already been introduced in the cement industry and describes a wide range of concepts that could be implemented in the future to increase sustainability in the cement industry. The intentions are to (1) document the current state of innovation and (2) provide ideas that could stimulate corporate thinking about sustainability-focused innovation in the cement industry over both the short and long term. There is no intent to provide a comprehensive list of every possible innovation that could lead to sustainability or to prescribe a pathway to sustainability that could be universally adopted by all cement companies. But examples of innovations where information was readily available have been included to illustrate possible pathways to increased sustainability.

The investigations conducted for this study involved four major activities:

1. **A literature review**, including journals, conference proceedings, books and websites related to innovation in general and to technology and management trends in the cement industry related to sustainability
2. **Interviews with cement company executives**, including R&D directors and managers involved in plant operations, technology implementation, human resources, logistics, and other aspects of operations. The interviews were conducted using a standard protocol. Company executives were asked not only to provide examples of innovative technologies and management practices, but also to provide general information about the drivers, enablers, obstacles and general climate for innovation in their companies. These interviews were conducted in person or over the telephone. In some cases, cement companies involved in the study provided written responses instead of giving interviews.
3. **Interviews with people involved in research** related to cement production and products, including cement associations, professors in academia, and vendors. These interviews were conducted primarily over the telephone and email.
4. **Dialogues with stakeholders** were held worldwide to gather information about their interests and concerns about the cement industry. Each of the stakeholder dialogues discussed innovation in small groups, along with other sustainability topics. Notes from those meetings were reviewed to provide the stakeholder perspective on innovation.

The examples of innovations found through all four routes were documented, either as short descriptions or as longer case studies that go into more depth. The report does not attempt to document all technologies, practices and pathways; nor does it make specific recommendations about which process, product or business strategy innovations individual cement companies should pursue. Company-specific factors must be included in such strategy decisions. Although detailed cost-benefit analysis of the options is beyond the scope of the study, the report does describe the overall benefits and economic aspects of various categories of innovations, and provides recommendations for how cement companies can evaluate potential innovations from a sustainability viewpoint. The report aims to offer cement companies sound ideas for innovation directions that could lead to sustainability, and points to areas of long-term research that cement companies might pursue jointly. Finally, the report offers practical advice about how cement companies can create an environment within their organizations that fosters and enables sustainability-focused innovation.

The findings of the study are summarized in the remainder of the report:

- **Section 2: Current Status of Innovation in the Cement Industry: Where Does Sustainability Begin?** This section expands the discussion of innovation drivers, barriers and enablers within the cement industry. This section also documents a sample of the many sustainability-oriented innovations that have been implemented in the past by one or more cement companies.
- **Section 3: Innovations Toward a More Sustainable Cement Industry: What are Some Pathways on the Journey?** This section discusses categories of innovation that might lead toward sustainability, and some specific examples within the categories
- **Section 4: Creating Sustainability-Focused Innovation Within the Cement Industry: How Can A Company Get There?** This section provides ideas for how innovation can be fostered within cement companies.
- **Section 5: Recommendations** – This section summarizes the findings of the investigation and suggests future actions that individual companies and cement companies working together could pursue in an effort to move toward sustainability.
- **Section 6: References**

- **Appendices A-B** – These appendices document the information gathered during the course of the study. Appendix A provides a catalog of examples of innovations discovered during the research. It does not include every technology or practice that can be considered innovative. Many innovations under development are proprietary. However, it does include a sample of innovations from three major aspects – (1) process, (2) product and (3) Business innovation. Appendix B contains two detailed innovation case studies.

2. Current Status of Innovation in the Cement Industry: Where does Sustainability Begin?

Over the course of the last few decades, the cement industry has invented or implemented numerous practices and technologies that improve environmental performance and make contributions to society. This section provides an overview of this progress to date. It discusses the perceived drivers for and impediments to innovation in the cement industry, and some of the things cement companies have done to foster or “enable” innovation. Then, some examples of steps cement companies have taken toward sustainability are summarized (more detail is provided in Appendix A). The types of innovations discussed fall into three categories:

- Process changes that reduce environmental impacts
- Product changes that improve environmental characteristics (compared to ordinary Portland cement) or that have other benefits to society
- Innovations in management, organizational behavior, and new business strategies that move companies toward sustainability (these will be collectively called *management innovations* here)

All of the innovations discussed in this section are related to sustainability, because they have environmental and/or social benefits. However, few of the innovations would be considered radical or breakthrough innovations from a sustainability perspective, because they have resulted in incremental changes in resource consumption or other impacts, rather than changes on the order of factor four or ten (see Section 1). Possible future directions for innovation that would lead to more radical changes in the environmental profile or societal benefit of cement are discussed in Section 3.

One objective of the research was to better understand the reasons the sustainability-oriented innovations had been conceived and implemented (we call these the “drivers” for innovation) and what impediments stand in the way of increased sustainability-oriented innovation. In addition, we found examples of practices, tools, and systems cement companies put in place to assist in their sustainability and innovation efforts (called “enablers”). Drivers, impediments, and enablers are discussed in the first three sections (Sections 2.1, 2.2, and 2.3), and Section 2.4 provides examples of process, product and management innovations that have already been implemented by cement companies as a start along the path toward sustainability.

2.1. Drivers of Innovation

Our research (based on interviews with cement company managers) shows that cement companies are usually motivated to innovate for one or more of the following reasons:

1. **Innovations can reduce operating costs or lead to higher-margin products, i.e., they can add to profitability or competitiveness.** Lowering operating costs is an obvious way to increase profitability (as long as the product price does not also drop). Increasing efficiency and decreasing energy and resource use almost always lead to decreased emissions and environmental impacts. In addition, many cement companies are attempting to produce products with special features that command higher prices. In some cases, higher value products have some type of environmental or societal benefit, though this typically has not been the principal driver for the change.
2. **Some innovations were driven by regulatory/legal pressures.** Environmental regulations have pushed cement companies to introduce pollution control devices and change many practices. In some cases, cement companies have adapted pollution control technologies from other industries (for example, flue gas de-sulfurization devices have been installed in a few cement plants; this technology was adapted from the electric utility industry). The threat

of regulation can be a motivator for innovation; for instance, some cement companies are concerned about the threat of climate change regulation, and are instituting and/or exploring ways to reduce carbon dioxide emissions.

3. **In some locations where resources are quite limited, cement companies are motivated to innovate to compensate for that scarcity of resources.** Land for waste disposal is one example of a scarce resource that has encouraged innovation. This driver is prevalent in countries such as the Netherlands and Japan, where land is scarce. Japanese companies have been encouraged to use wastes as fuel, eliminating the need for land disposal of those wastes. In the Netherlands, the shortage of land and other factors have resulted in regulations requiring the use of demolition waste, encouraging innovations in concrete recycling. In such countries, the governments support and the public is willing to accept innovations aimed at reducing land and resource use. ^{††}
4. **The companies think that innovations aimed at environmental and societal innovations are the “right thing to do.”** Companies feel that when they make good faith efforts to improve environmental performance or take initiatives to help communities in which they operate, they receive benefits that are hard to quantify— a better company image, improved employee loyalty, and a more highly ensured “right to operate.” Corporate image is especially important when a company is attempting to site new facilities in developing countries, which are expected to have the highest growth in cement demand in the future.

During the course of our interviews, no company executives mentioned serious concern about competition from new methods of producing cement or substitute cement products (e.g., geopolymers). In other words, the threat of disruptive innovation^{††} does not appear to be a primary concern to cement companies today. However, some interviews indicated cement companies are concerned about competition from current concrete substitutes, such as asphalt for road applications, and steel and wood for building construction. And in general, the competition among cement companies for market share is an underlying reason for the drivers described above.

2.2. Impediments to Innovation

Innovation is risky. The interviews conducted during this study indicate that customers of the cement industry and the cement industry itself can be averse to risk and tend to resist change. Resistance to change is not unique to the cement industry (see box).

A principal barrier to innovation in

Why Strategic Innovation Isn't Easy for Established Companies

“Established players already occupy a certain strategic position and may have difficulty escaping their mental models of who their customers really are and what they should be offering those customers. ... [Also], established competitors already have a business position to take care of. If they are to strategically innovate, they may have to manage their existing position while simultaneously moving into a new strategic position – no easy task... The obstacles to innovation grow even more formidable when a company's existing position is quite profitable and successful. [S]uccess is almost always accompanied by numerous negative side effects, such as complacency, self-satisfaction, managerial overconfidence, and even arrogance... For a company even to begin to search for new strategic positions, let alone discover them, it must first overcome these barriers.”

Reference: Markides.¹⁴

Note: Markides is a Professor and Chairman of the Strategic and International Management Department at the London Business School.

^{††} Some business strategists view the scarcity of resources and strict environmental regulations as a competitive advantage to some nations, in that they force industries to innovate, which often leads to reduced costs or other benefits, and increases competitiveness with industries in countries that do not feel these pressures.¹³

^{††} Disruptive innovations bring to market very different products or services that typically undermine established products and services in the particular market sector.⁹ See Section 1.

the cement industry is the desire to maintain the market for Portland cement in order to recoup very large investments in Portland cement production facilities. Cement production is one of the most capital-intensive industries; a large cement plant costs over 150M Euros per million tonne of annual capacity, equivalent to approximately three years of turnover.⁶ Major plant modifications are also expensive. The long time period required to recoup investments in cement plants leads to careful planning of modifications and a conservative attitude toward change. Additionally, in markets that are not growing, cement companies may face a scarcity of investment capital.

Customers, too, are wary of changes in the cement they trust and are accustomed to using. Standards and building codes have been developed over the years to prevent untested innovations from adversely affecting the safety of buildings and other structures. But the same standards that help the industry succeed can also be impediments to introducing innovative products. The standards barrier could be broken or circumvented by a strong desire for change. Concerted efforts and industry consensus are required for some barriers to be broken. For instance, several Japanese cement companies found that Japanese Industrial Standards restricted the use of cements containing wastes (e.g., EcoCement) and worked with government officials to change the standards. Market pressures can also affect change. For example, as consumers of cement and concrete become more aware of sustainability issues, specifications may increasingly call for blended cement products that have been approved under new standards. (See box on page 1, which documents the view of Holliday and Pepper that **informing customer choice** is one of the seven keys to success for sustainability through the market.) In some cases, governments can provide additional mechanisms for companies to gain approval for introduction of innovative products. In Europe, for instance, an innovative cement product can be approved using European Technical Approval or National Technical Approval instruments (see box below).

European Technical Approval (ETA)

An European Technical Approval (ETA) for a construction product is a favorable technical assessment of its fitness for an intended use, based on the fulfillment of Essential Requirements as stated in the Construction Products Directive (89/106/EEC) for the type of construction in which the product will be used.

An **ETA** can be granted when any of the following conditions apply:

- No relevant Harmonized Standards for the product exist
- The European Commission has given no mandate for such a standard
- The European Commission does not think a Standard can be yet developed within a reasonable time
- The product deviates significantly from the relevant Harmonized Standards

In conjunction with an Attestation of Conformity procedure, ETA allows a manufacturer to place a CE (European Commission) mark on the product. A product approved using National Technical Approval, which is a similar assessment utilized at national level, cannot use the CE marking.

Companies (e.g., Italcementi) have used such instruments for launching some new products that are not covered by conventional standards.

2.3. Enablers of Innovation

Many cement companies, aware that innovation is an important element of success, have put in place mechanisms to foster innovation and sustainability. For instance, some companies:

- Hold periodic across-company conferences or meetings to pass along innovations
- Develop intranet sites to share innovation case studies
- Hire people from research institutes to foster an innovative “attitude”
- Give awards for employees who show great initiative
- Institute best practices programs to share successful strategies with others in the company (for example, see box below).
- Set up pilot programs to demonstrate innovative approaches related to sustainability
- Institute “technical intelligence” and patent evaluation programs to scan for new technologies and approaches outside their companies

Changing the culture within cement companies to foster innovation will be important as the industry moves toward increased sustainability.

Case Study: Best Practices Programs

Votorantim (a cement company based in Brazil) has a strong Best Practices Program that includes a Special Team organized to identify, evaluate and recommend cement industry best practices. They identifying a particular best practice in the cement industry, compare it to the practice at Votorantim plants, and then analyze the data to see the technology improvement would be beneficial to Votorantim. Once the Best Practices Special Team has identified opportunities for change, it provides information to the plant managers. Plant managers interested in implementing changes must request funds from the corporate office. The Best Practices Special Team establishes the priorities and evaluates ideas at the corporate level. The Special Team checks in on the progress of the individual plants first to document any difference in performance and/or to help with the implementation and initial operation of the equipment. The Votorantim program has been universally accepted throughout the company (almost all employees are involved), and there are rewards associated with it. Employee salaries are fixed and variable, and the variable portion of the salary is sometimes tied directly to the successes implemented through this program. Many other cement companies have “best practices” programs.

2.4. Current Status of Sustainability-Oriented Innovation in the Cement Industry

Cement companies have introduced many innovations that result in better environmental performance, lower resource consumption, and other societal benefits. Table 2-1 shows the type of progress that has been exhibited with respect to the sustainability issues discussed in Section 1. A few of these innovations are highlighted in case study boxes at the side of the table, and more examples are included in the Appendix.

Table 2-1. Innovations that Have Been Implemented in the Cement Industry

Issue	Progress to Date
<p data-bbox="128 310 380 375">Resource Productivity</p> <p data-bbox="128 402 380 521"><i>Lowering fossil fuel and natural resource consumption</i></p>	<p data-bbox="380 310 1159 342">Process Innovations:</p> <ul data-bbox="380 342 1159 1408" style="list-style-type: none"> <li data-bbox="380 342 1159 613">▪ Many cement companies have initiated cement production process improvements leading to energy efficiency in both new and existing plants, lowering virgin fossil fuel use. Such improvements include increasing pre-heater stages, optimizing heat recovery in clinker coolers, using high-efficiency classifiers/separators and variable/adjustable speed drives, installing pre-calciners, replacing raw meal and finish grinding mills with more efficient ones, using grate coolers, upgrading motors, etc. <li data-bbox="380 613 1159 829">▪ Improved process control has lowered energy usage at many plants by optimizing plant operations and raw material use, thus increasing productivity. Neural networks, 'smart' devices, artificial intelligence, and on-line monitoring equipment are some of the tools that are being credited for up to 10% in fuel savings and 3-4 kWh per tonne of clinker in electricity savings.⁷ <li data-bbox="380 829 1159 1166">▪ Alternative energy sources, such as waste tires, have become quite commonly used in cement plants, reducing the need for virgin fossil fuels. Some innovative alternative fuels are produced from waste products (e.g., Refuse-Derived Fuel, derived from household waste (see box, next page), and Profuel, which is made from non-recyclable paper, plastics and carpet –see Appendix A). In a few cases, cement plants have experimented with using renewable energy (e.g., wind- or hydro-power) to supplement electricity from conventional plants (see Appendix A for an example). <li data-bbox="380 1166 1159 1284">▪ Transportation energy use has been reduced by altering modes of transportation (e.g., using more rail and barge transport, and less trucking) and through logistics optimization. <li data-bbox="380 1284 1159 1408">▪ Depletion of water from natural water bodies has been decreased at some cement plants through use of stormwater and innovative cooling water circuits (closed loop systems) – see box on page 14.

Case Study: Horomill Grinding Technology

The Horomill has been documented to reduce electricity usage up to 40% for cement grinding (when compared to ball mills). It is cost competitive with other grinding technologies and is designed for operational flexibility. The technology uses a roller in the inner part of the shell turning at high speed and applies downward pressure to the roller. The material to be ground is scraped down several times under the roller, so multi-compression of the particles occurs during a single cycle. The roller presses on the concave surface of the shell, rather than on the convex surface of another roller; therefore, the compression surface is three to four times greater. Stresses on the equipment are reduced in proportion to the increase in the compression surface increase. See Appendix B.2 for more detail.

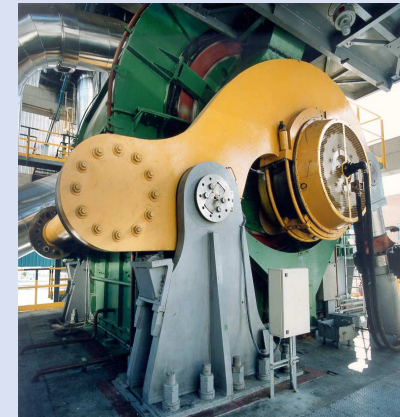

Table 2-1. Innovations that Have Been Implemented in the Cement Industry

Issue	Progress to Date
	<p>Product Innovations:</p> <ul style="list-style-type: none"> Limestone consumption per tonne of cement produced decreases when Portland cement is blended with other pozzolanic or cementitious substances, such as fly ash, granulated blast furnace slag (see box on page 14), or other waste-based products (e.g, cement produced from household wastes – see Appendix A). Many cement companies are marketing blended or composite cements that include these other substances. In addition, some companies market pure waste-based cement products, such as sulfur concrete (see Appendix A). Some innovative cement companies have used municipal solid waste and contaminated sludge and soils or municipal solid waste incineration ash as an alternative feedstock, or used treated sewage an additive to cement (see Appendix A). Some have used de-sulfurized power plant wastes as source of gypsum. Increasingly, cement companies are installing specialized equipment, such as on-line raw material analyzers using mass spectroscopy and chlorine by-pass or washing systems to control and assess the material content and quality of raw materials entering the kiln, which helps control the quality of cement that incorporates waste. <p>Management Innovation:</p> <ul style="list-style-type: none"> Some cement companies have worked together to centrally site a group of cement plants near other industries, environmentally preferred transportation, natural resources, and/or energy source(s) to make it easier to develop alternative energy sources and industrial ecology approaches (Also Appendix A and SS9: Industrial Ecology)
<p>Climate Protection</p> <p><i>Reducing CO₂ emissions</i></p>	<p>Process innovations:</p> <ul style="list-style-type: none"> Improved energy efficiency and process control that result in lower energy consumption, described above under “Resource Productivity,” almost always reduce fossil fuel consumption. Use of alternative fuels that would otherwise be incinerated may also provide an offset of CO₂ emissions. (Although the CO₂ emissions from the cement plant itself do

Case Study: Refuse Derived Fuel

The Japanese government is promoting Refuse Derived Fuel (RDF) involving the conversion of municipal waste into fuel. Taiheiyo is producing and using RDF thereby reducing fossil fuel consumption and CO₂ emissions. RDF is easy to store and transport and the resulting ash after burning is incorporated as a cement raw material. RDF is prepared by crushing the municipal waste and removing the incombustible material. Calcium oxide (CaO) is added to absorb moisture and act as a sterilizing agent. The RDF is molded into a cylinder for safe and easy use.

Reference: Taiheiyo Cement Corporation, “Introduction to Environmental Technologies”¹⁵

Case Study: Systems Approach to Water Use Management

The Rüdersdorfer Zement plant (RMC) used to take over three million cubic meters of water per year from the nearby Stienitzsee Lake as cooling and production service water. The plant took steps to reduce the amount of water taken from the lake by establishing a cooling water circuit (including cooling towers) and constructing a rainwater-collection tank. This tank provides the opportunity to use rainwater instead of lakewater. The tank uses an oil detector to monitor the presence of oil and prevent the lake from being polluted in the case of an oil accident. As a result of the integration of these measures, water extraction from the Stienitzsee was reduced to less than one million cubic meters in 1999 and will be reduced to less than 0.5 million through further optimization.

Note: other companies use similar approaches. Reference: Ruderdorfer Zement GmbH.¹⁶

Table 2-1. Innovations that Have Been Implemented in the Cement Industry

Issue	Progress to Date
	<p>not necessarily decrease when these alternative fuels are used, overall regional CO₂ emissions decrease in some cases because of the reduced incineration, and cement plants may be able to obtain emission offset credits in these cases -- see SS8: Climate Change).</p> <p>Product innovations: The trend towards sales of <i>blended/composite and alternative cements</i> has slowed the increase in CO₂ emissions from cement manufacture, because it reduced the amount of limestone that had to be calcined. (Also see SS8: Climate Change.)</p>
<p>Emission Reduction</p> <p><i>Reducing water and air pollutants</i></p>	<p>Process innovations:</p> <ul style="list-style-type: none"> ▪ Cement companies have increasingly installed air pollution control devices including bag (fabric) filters and electrostatic precipitators for particulate matter; flue gas desulfurization devices (scrubbers) for SO_x emissions, and low-NO_x burners, wastewater or ammonia injection and, sometimes, selective non-catalytic reduction (SNCR) for control of nitrogen oxides. These technologies have generally been adopted from other industries, such as power generation. The use of more advanced technologies, such as pulse-jet bag filters, has been extended in the last few years to more sources within the plants (e.g., pulse-jet filters have been used on mills, coolers and transport systems for years, but only in the last few years have they begun to be installed on kiln exhaust gas). ▪ Air pollution monitoring has also become more widespread in the cement industry. Some companies are developing sophisticated, integrated monitoring systems. (see box on next page) ▪ Water pollution reduction has been implemented by adding storm water management systems to control runoff and wastewater management/recycling systems. <p>(Also see SS 10: Environment, Safety and Health)</p>

Case Study: GranCem Granulated Blast Furnace Slag (GBFS)

Many cement companies make products that incorporate a co-product of ironmaking – granulated blast-furnace slag. Blast-furnace slag is the nonmetallic product consisting primarily of silicates and aluminosilicates of calcium and other bases that is developed in a molten condition simultaneously with iron in a blast furnace. It is rapidly chilled (e.g., by immersion in water) to form a glassy, granular material called granulated blast furnace slag. One such product is GranCem, marketed by the Holcim Group Companies – Holcim (US) Inc., APASCO and St. Lawrence Cement. GranCem is ground granulated blast furnace slag (GGBFS) that typically replaces, kilo-for-kilo, a portion of the Portland cement in concrete mixtures. It improves concrete workability and finishability, lightens the hardened cement color, increases strength, reduces permeability, and enhances protection in applications where sulfate resistance and resistance to alkali-silica reactions are important. In addition, some people consider it a “green” product, because using it reduces the amount of Portland cement needed, and hence lowers the energy consumption and emissions associated with Portland cement production. In the United States, the Environmental Protection Agency listed GGBFS as a recycled material, and its use helps contractors meet the minimum recycled material content requirements for construction projects funded by the US (federal) government.

Note: Other companies also offer similar products.

Source: www.grancem.com¹⁷

Table 2-1. Innovations that Have Been Implemented in the Cement Industry

Issue	Progress to Date
<p>Ecological Stewardship</p> <p><i>Preventing damage to ecosystems and promoting use of cement to prevent or ameliorate ecological threats</i></p>	<p>Process Innovations:</p> <ul style="list-style-type: none"> Many cement companies have made progress in reducing impacts on ecosystems by better planning and operating quarries and carefully siting new ones. Innovations in this field include use of models and software (e.g., geo-statistical techniques that permit the use of extracting reserves and the establishment of specific mining extraction plans), use of the linear extraction method for quarrying, and progressive quarry reclamation. New quarrying techniques, such as semi-open cut mining, have been invented to reduce disturbance of the natural environment (see box on next page). Also see SS 11: Land Use and Biodiversity. <p>Product Innovations:</p> <ul style="list-style-type: none"> Cement has been used to ameliorate or prevent damage to the environment. For example, cement products have been applied to treat contaminated soils, and to isolate radioactive, incinerator, and other wastes (Appendix A). <p>Management Innovations:</p> <ul style="list-style-type: none"> Some companies have avoided disturbing pristine land by using brownfields and other low-impact locations for new and modified facilities, and extending the life of older facilities. In addition, some companies have used of old cement kilns as composting and waste processing sites (See Appendix A. Also see SS 9: Industrial Ecology)
<p>Employee Well-Being</p> <p><i>Creating a high-quality, safe work place and development opportunities for employees</i></p>	<p>Management Innovations:</p> <ul style="list-style-type: none"> Many companies monitor worker health and safety conditions, including noise levels and other aspects of plant operations (see SS 10: Environment, Health and Safety) Some cement companies provide training (including training related to sustainability issues) and help employees set goals for their career advancement. Innovative employee exchange programs, in which managers are rotated into different types of positions, have helped some cement companies retain their best employees

Case Study: Integrated Air Monitoring System

Cimpor-Indústria de Cimentos, S.A. has modern continuous emission monitoring systems on every fixed air pollutant source. Particulates are monitored at every fixed source (kiln stacks, kiln coolers, cement and coal grinding plants and stacks). In addition, NO_x, CO and SO₂ are monitored in every kiln stack. Each one of the Portuguese facilities has an air emissions management and control information system, installed in the Central Control Room, with two different types of software: GEAT and SolAr. GEAT is used for data acquisition from the continuous monitoring equipment installed in stacks. This system allows real-time monitoring of gas flow, NO_x, CO and particles for the kilns, and flow and particles for the remaining emission sources. SolAr allows for the standardization and treatment of the different parameters and provides the data in a variety of useful formats.

In addition, the company installed air-quality monitoring stations at five fixed sites around the plants, which were determined based on particulate plume dispersal studies. The monitors are equipped with high-volume particulate retainers and register the wind direction and speed to allow for a better interpretation of data. TSP and PM-10 measurements are carried out.

References: Cimpor,¹⁸ Rocha.¹⁹

Table 2-1. Innovations that Have Been Implemented in the Cement Industry

Issue	Progress to Date
<p>Community Well Being</p> <p><i>Improving the quality of life within communities</i></p>	<p>Process innovations: In addition to improving air and water quality (discussed above), cement companies have initiated other activities that improve community well being:</p> <ul style="list-style-type: none"> ▪ Innovative noise reduction practices involve a holistic analysis of plant noise (e.g., creating an acoustic map of the cement plant to help prioritize noise reduction initiatives). Noise management practices that have been put in place also include blasting at micro-intervals, seismograph recording, enclosing mills inside buildings, using silent blowers and ventilation equipment, etc. ▪ Many plants have reduced truck traffic by using conveyor belts (sometimes partially underground) or by increasing use of barges. ▪ Cement kilns have also been used as a mechanism for destroying hazardous materials, which offer a fuel source for the cement industry and waste management for the community. Hazardous chemicals, CFCs (see Appendix A), organic wastes and non-recyclables are examples of the materials that can be destroyed in cement kilns. This provides a service to communities (and society, in general). <p>Product innovations:</p> <ul style="list-style-type: none"> ▪ Advancements in concrete products, often developed or supported by cement companies, have helped reduce disturbance associated with construction. For instance, self-leveling and self-compacting concretes can significantly reduce noise associated with concrete applications (see Appendix A.) <p>Management Innovations:</p> <ul style="list-style-type: none"> ▪ Cement companies are increasingly engaging in a positive way with communities through stakeholder dialogue (see SS1/2:Stakeholder Dialogue and Communication) ▪ Some cement companies operating in developing economies provide support or aid to local communities, e.g., by donating cement for construction projects, providing funds for community projects, supporting local businesses, etc. (See Appendix B.1.)

Case Study: The Semi-Open Cut Mining Technique Invented by Siam Cement Industry

Siam Cement Industry located a new plant in Lampang, Thailand, at the center of an agricultural area. The company wished to preserve the natural landscape as much as possible and minimize environmental impacts. To meet this goal, the company designed an innovative method of quarrying, called “semi-open cut mining.” This quarrying technique is a combination of the two traditional methods known as open pit mining and open cut mining. The mining operation occurs in the exposed area, and the level of the mining is adjusted downward as the limestone is removed. This creates an effect that looks like the rows of seats in a sports stadium inside the quarry. On the outside, the outer inclined shell of the mountain remains intact. The inner crust is excavated, but the shell is left wide enough to retain a stable shape that will not later cave in. This method makes it easier to fill soil on top of the excavated areas and promptly plant vegetation, instead of reclaiming the quarry at the end of its life.



Reference: Dumrongsak²⁰

Table 2-1. Innovations that Have Been Implemented in the Cement Industry

Issue	Progress to Date
<p>Regional Development</p> <p><i>Supporting sustainable economic development</i></p>	<p>Product Innovation:</p> <ul style="list-style-type: none"> ▪ Progressive cement companies have developed new products that make construction projects easier, improve aesthetics and the quality of life in built environments. Examples include: Ductal Concrete and Plantation Concrete marketed by Taiheiyo (See Appendix A). ▪ Some currently available products can extend the life of existing structures, e.g., magnesium phosphate cement composites and polymer concrete applied to surfaces (Appendix A). In addition, concrete can be formulated for a longer lifetime (see Section 3.2 for further discussion of this issue). Such practices not only reduce infrastructure-development costs (often borne by the government), but decrease the demand for Portland cement, hence decreasing, on a lifecycle basis, resource use and emissions.
<p>Shareholder Value</p> <p><i>Improving profitability and sustaining corporate growth</i></p>	<p>Process innovation:</p> <ul style="list-style-type: none"> • Many of the innovations described above have led to reduction in operating costs. For example, energy efficiency measures lower energy costs. <p>Product Innovation:</p> <ul style="list-style-type: none"> ▪ Some environmentally- or socially-beneficial products also command higher prices. For example, a high-value cement product that has environmental benefits is cement containing titanium dioxide. <p>Management innovation:</p> <ul style="list-style-type: none"> ▪ In addition to process or product changes, some cement companies have expanded the scope or changed the emphasis of their business. Some (e.g., Taiheiyo) have expanded the scope of the cement business to include waste management and recycling precious metals from combustion ash (See Appendix A.) Others (e.g., CEMEX) have entered into businesses related to cement production, such as electronic cement commerce (see box next page)

Case Study: Ductal Concrete

Ductal[®] developed by Bouygues, Lafarge and Rhodia is an Ultra- High-Performance Concrete. It is a ductile material capable of resisting substantial flexural loads, and it does not require passive reinforcement. This enables the overall thickness of structural elements to be reduced, and therefore allows greater freedom of form. The material extremely durable is also aesthetically pleasing.

Note: Other companies also offer similar products.

Reference: Picard²¹

Case Study: Cement Containing Titanium Dioxide

To help reduce air pollution and prevent the discoloration of urban concrete surfaces, several cement companies, including Italcementi and Taiheiyo, have marketed cement containing a photocatalyst (titanium dioxide) that removes certain air pollutants – volatile organic compounds – from the atmosphere and converts them to CO₂. The product marketed by Italcementi is called Millenium cement. If put into widespread use, such cement could potentially have a positive impact on urban air quality (smog). (The CO₂ produced would be very small compared to CO₂ from combustion sources.) Italcementi is currently promoting a paint based on Millenium cement to be used on the surface of buildings. Millenium cement will be sold at prices higher than normal Portland cement. The use of cementitious materials containing photocataysts is an innovative and profitable way to eliminate pollutants and contribute to aesthetics.

Reference: Cassar et al.²²

(HOW INNOVATION CAN HELP THE CEMENT INDUSTRY MOVE TOWARD MORE SUSTAINABLE PRACTICES)

Ventures into E-Commerce

Like several other cement companies, Cemex has launched into the Internet and e-commerce with a new division, Cx Networks, and four initiatives: information technology consulting, a construction materials online marketplace, office supplies online marketplace, and investment in an Internet incubator. Cemex estimated that by the end of 2001, more than 50% of its operations will be conducted online and that Cx Networks will save the company \$120 million annually. E-commerce can improve efficiency in logistics and shipping, and hence can reduce energy and emissions associated with these activities.

Reference: Helft²³

3. Innovations Toward a More Sustainable Cement Industry: What are Some Pathways on the Journey?

As discussed in Section 2, the cement industry has made progress toward sustainability. This section describes more advanced and sometimes radical future pathways for improving the environmental and social impacts of cement production and use, which could lead the industry toward a more sustainable future. Each company must choose its own pathway to sustainability, so the innovations in this section are framed as things companies could do, rather than things they should do.

The concepts presented here do not represent the only possible sustainable cement innovations. Instead, they are presented to stimulate thinking and provide a general idea of possible directions toward sustainability. Cement companies themselves are in the best position to conduct research aimed at inventing, testing, and evaluating potential sustainable pathways. Innovations that are under development are usually proprietary to individual companies, and some companies would be hesitant to publish them in a public forum like this.

The discussion in this section is organized into three innovation categories: (1) innovations in the production process, i.e., the way cement is made (Section 3.1); (2) innovations in the product – in both the product characteristics and the way the product is used (Section 3.2), and (3) innovations in the way cement companies do business, i.e., innovations in management practices and business concepts (Section 3.3). The distinction among the three categories is somewhat artificial. For instance, new business concepts may involve product or process changes, and new products often involve new processes, etc. But the three categories provide an organized way to describe the pathways.

The following table summarizes how the innovation pathways discussed in this section relate to the eight sustainability issues discussed in the previous two sections. Innovations in some categories are covered in depth in other **studies**, so they are only briefly mentioned here. For other issues, we simply recommend more widespread use of the past innovations discussed in Section 2.

Table 3-1. Potential Future Innovation Pathways	
Issue	Potential Innovation Pathways Toward Increased Sustainability
Resource Productivity	<p>Process:</p> <ul style="list-style-type: none"> ▪ Technologies for safely increasing use of waste fuels in kilns (see Section 3.1) ▪ Advanced monitoring for combustion processes using wastes (Section 3.1) ▪ Co-production of cement and electricity (Section 3.1) ▪ Advanced kiln concepts that lower temperature or fossil fuel use (Section 3.1) <p>Product:</p> <ul style="list-style-type: none"> ▪ Innovations that lead to much lower use of limestone in cement by increasing performance of blended/composite cement or concrete (Section 3.2) ▪ Novel cement products using fewer virgin resources (cement with lower calcium content or higher reactivity; new types of cement made by completely new processes) (Section 3.2) <p>Management:</p> <ul style="list-style-type: none"> ▪ Use of lifecycle analysis and other analysis techniques to better understand the relative impacts of various possible resource productivity improvements (see SS 6: Life Cycle Assessment)

Table 3-1. Potential Future Innovation Pathways	
Issue	Potential Innovation Pathways Toward Increased Sustainability
Climate Protection	<p>The items discussed under “Resource Productivity” also apply to “Climate Protection.” In addition:</p> <p>Process:</p> <ul style="list-style-type: none"> Development of biomass fuels for cement kilns (see Section 3.1 and SS8: Climate Change) Use of lower-carbon, hydrogen-rich fuels (Section 3.1) Carbon capture and sequestration technology (see Section 3.1 and SS8: Climate Change) <p>Management</p> <ul style="list-style-type: none"> Measurement and monitoring programs for CO₂ (see SS8: Climate Change) Development of CO₂ offset programs, in collaboration with governments (see SS8: Climate Change)
Emission Reduction	<p>Process:</p> <ul style="list-style-type: none"> Continuous improvement in emission reduction technology (see Section 3.2 and SS10: Environment, Health and Safety) <p>Management:</p> <ul style="list-style-type: none"> More widespread use of continuous emissions monitoring and environmental management systems (see SS10: Environment, Health and Safety)
Ecological Stewardship	<p>Management:</p> <ul style="list-style-type: none"> More widespread use of good land use practices (see SS11: Land Use and Biodiversity) and expanded use of new quarrying techniques, such as semi-open cut mining
Employee Well Being	<p>Management:</p> <ul style="list-style-type: none"> Improved methods to measure and ensure worker safety, including the handling of wastes (see SS10: Environment, Health and Safety).
Community Well Being	<p>Process:</p> <ul style="list-style-type: none"> Innovative ways to destroy hazardous substances in cement kilns, providing a benefit to society (Section 3.1) <p>Product:</p> <ul style="list-style-type: none"> New applications of cement to ameliorate environmental problems (Section 3.2) <p>Management:</p> <ul style="list-style-type: none"> Innovative stakeholder communication methods (see SS1/2: Stakeholder Dialogue and Communication) Better ways to evaluate benefits to society of waste destruction and other innovations (Section 4)
Regional Development	<p>Product:</p> <ul style="list-style-type: none"> Novel cement-based products that lower costs of infrastructure development in emerging economies (Section 3.2) Cement products that can extend the life of existing structures, and better scientific understanding to evaluate of life extension strategies (Section 3.2)
Stakeholder Value	<p>Process:</p> <ul style="list-style-type: none"> Continuous improvement in process efficiency and cost reduction <p>Product:</p> <ul style="list-style-type: none"> High-value products that have environmental and societal benefits (Section 3.2) <p>Management:</p> <ul style="list-style-type: none"> New business models that change the way shareholder value is produced by cement companies (see Section 3.3)

3.1. Process Pathways Toward Sustainability

Process innovation pathways that could lead to greater sustainability are described below. More detail on the individual technologies may be found in Appendix A.

- **Enhanced use of waste and biomass fuels in kilns.** Increasing the use of non-fossil fuels can make a cost-effective contribution to sustainability, provided the use of these alternative fuels does not have its own negative environmental or societal effects. Using

waste fuels reduces fossil fuel consumption, and can provide an offset of CO₂ emissions. Under some conditions, use of wastes can also reduce air pollutant emissions²⁴ (see Appendix A). Innovations related to pre-processing wastes (see an example in box below) to remove harmful substances and/or recover valuable materials from the wastes could be explored. Changes to the kiln to facilitate use of biomass fuels, which produce almost zero net CO₂ emissions,^{§§} could also be investigated.

- **Monitoring technologies for waste combustion.** In some countries, the public has expressed considerable concern over possible dioxin and furan emissions from cement kilns that use waste fuels, though testing has shown that proper use of these fuels creates emissions low enough as not to be inimical to human health (see **SS10 : Environment, Health and Safety**). Cement companies that use waste fuels should conduct or support additional research/testing and use advanced monitoring techniques to improve knowledge about releases from these fuels.

Case Study: Circulating Fluidized Bed Technology at Rüdersdorfer

The Rüdersdorfer plant (RMC) uses waste material to supply both fuel and raw material components. Waste fuels, such as sorted light fractions from mixed waste, are gasified in a circulating fluidized bed together with carbon-containing waste mineral sources, such as ash, foundry sand or oil-contaminated soil. The process breaks down the wastes into combustible and mineral constituents. The resulting gas is used in the kiln as fuel, and the burned-out ash is sent as a raw material component to the raw mill to become clinker.

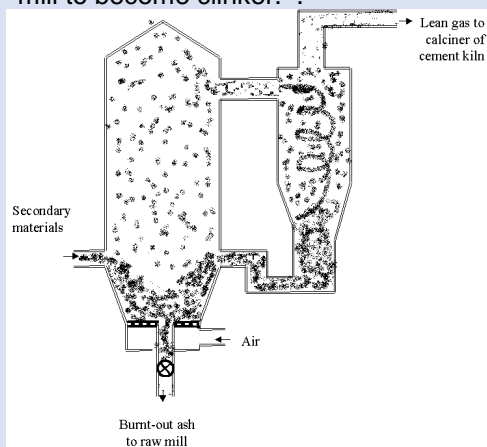

Source: Rüdersdorfer Zement GmbH.¹⁶

- **Advanced kiln concepts.** One experimental technique to lower kiln temperatures involves introduction of fluorspar, CaF₂ or organometallic substances in the kiln. However, the high cost of these additives makes this technique cost-prohibitive under current circumstances. Research at the Paul Scherrer Institute in Switzerland indicates that the incorporation of solar energy into the cement production process is technically feasible,^{26,26} though this technology has limited range of use and is not cost competitive. Another kiln design, the fluidized bed kiln, uses a stationary (rather than rotary) kiln in which the raw materials are calcined in a fluidized bed (this is similar to the approach presented in the RMC case study, but involves completely replacing the rotary kiln with a stationary fluidized bed.) The potential advantages of fluidized bed for cement production are lower capital costs, because of smaller equipment, lower flame temperatures resulting in lower NO_x emissions, a wider range of fuel that can be used, and lower energy use.²⁷ There have been some technical difficulties with the technology, and it is being commercialized primarily as a way to make clinker from cement kiln dust (CKD). More research could help make this technology more commercially attractive. A novel way to make cement involves use of an arc of plasma that is formed when electricity flows through a

gas. Plasma heating is capable of maintaining significantly higher sustained temperatures with lower energy consumption than other heating methods. Plasma arc furnaces are being

^{§§} Plants (biomass) incorporate (or 'sequester') carbon during their growth. Therefore, on a lifecycle basis (where the lifecycle includes both the period of biomass growth and its combustion), there is a near zero net emissions of carbon. (The net emissions are not *exactly* zero because some non-biomass fuel may be used in processing or transportation of biomass.) Theoretically, carbon dioxide emissions produced by the biomass combustion will be incorporated into new plants grown for future combustion uses.

promoted as environmentally-sound solutions for waste disposal, and plasma kilns have been investigated in the past for use in cement production.²⁸ Alternative ways of transforming cement precursors with less energy consumption, such as using **microwave technology**, could also be explored. The full advantages and costs of new methods cannot be known until more research is done. This kind of research may be done through industry consortia aimed at fostering environmentally sound novel cement production technologies.

- **Co-production of electricity and cement.** As discussed in Section 2, captured fly ash has been used in blended cements for many years, and it might be possible to use bottom ash as well. The potentially synergistic relationship between the two processes -- coal combustion and cement production -- presents an opportunity for innovative concepts. A simple innovation would involve co-location of power production and cement manufacture at the same site, making fly ash (and perhaps bottom ash,²⁹) easily accessible for production of blended cement. A more radical innovation, which has been tested and is being marketed in the United States and Canada, involves grinding a proprietary calcium-rich material together with coal (in approximately equal quantities) and burning the mixture in pulverized-coal-fired boilers (see box).
- **Use low-carbon, hydrogen-rich fuels for CO₂ control.** Increased use of natural gas and other low carbon fuels could lower CO₂ emissions. Use of methane collected from landfills offers some prospects for CO₂ reduction, while decreasing the escape of this greenhouse gas (methane), to the atmosphere.³⁰ Advances in the manufacture of hydrogen as a fuel offer the promise of a fuel with zero carbon. For instance, natural gas can be reformed to a mixture of H₂ and CO₂, and fuel oil and coal can be transformed by gasification to a mixture of mainly H₂ and CO. However, hydrogen production is currently a highly energy-intensive and expensive process, and it usually produces CO₂ that must be separated, and sequestered or used. In addition, the use of low- or zero-carbon fuels will only reduce combustion-related CO₂ and not affect the process-related emissions.

Case Study: A Process to Produce Clinker in Coal-Fired Boilers: Global New Energy

The “ash modifying compound” technology being licensed for development by Global New Energy Corporation (based in Delaware, United States) is based on the idea that both coal ash and cement clinker are created through high-temperature burning and both have the same basic chemical makeup. By adding an ash-modifying compound during coal combustion, the unburned ash becomes a calcium-rich crystalline belite clinker. Addition of the compound does not affect the production of electricity from the boiler, and as an added bonus, the process also decreases SO₂ emissions from the power plant. The technology has been demonstrated in China and is also being tested in the United States and Canada. The sustainability-related aspects include: elimination of bottom ash from the power plant, reduction in sulfur dioxide emissions from the power plant, decrease in the calcium (limestone) requirement for cement production, and elimination of carbon dioxide emissions from cement production (the process produces carbon dioxide emissions from a power plant only, instead of emissions from both power plant and cement production). Further refinement of the process, as well as product testing, is needed to gain more widespread use of this technology.

Reference: Put and Doerksen³¹

- **CO₂ separation, capture, and sequestration.** Carbon dioxide can be separated from the gas exhaust at industrial facilities using membranes, chemical absorption, or by modifying the combustion process to use oxygen instead of air.⁷ The technology is proven, although costs are currently high. The box on the following page explains one approach to CO₂ gas treatment using an amine system for scrubbing, together with membrane gas/liquid contactors. This is one of many separation concepts being explored. In addition to

separation, CO₂ would have to be compressed, transported, and disposed of in deep geologic formations, aquifers or other sinks, or used in enhanced oil recovery or some other productive use. (Some limited cement plant applications of enhanced oil recovery and other uses are already underway). Despite the fact that all of the methods are currently expensive, should carbon taxes become a reality or a breakthrough in technology occur, these methods could result in a cement kiln with very low net CO₂ emissions.

Case Study: CO₂ Separation

Kvaerner Oil and Gas, in cooperation with the technology partner W.L. Gore and Associates, has developed a technology for processing CO₂ gas.³² The technology uses a membrane gas/liquid contactor. The gas is scrubbed with an amine solution. The CO₂ reacts with the basic solvent, forming a salt complex. This step occurs in a tower (contactor) with a micro-porous membrane, which brings the gas stream and solvent liquid stream in intimate contact with each other, but keeps the gas and absorption liquid separated. After the salt complex is formed, the solvent is regenerated to its original form by application of heat in a second tower. (Once the solvent is removed, the resulting pure CO₂ stream would be deployed in a productive use, such as enhanced oil recovery, or disposed of in an appropriate geological formation or other repository.) A pilot scale unit for treating exhaust gas from a 520 kW gas engine has been in operation in Norway since 1998. A laboratory test unit has also been erected at the Foundation for Scientific and Industry Research (SINTEF) at the Norwegian Institute of Technology.

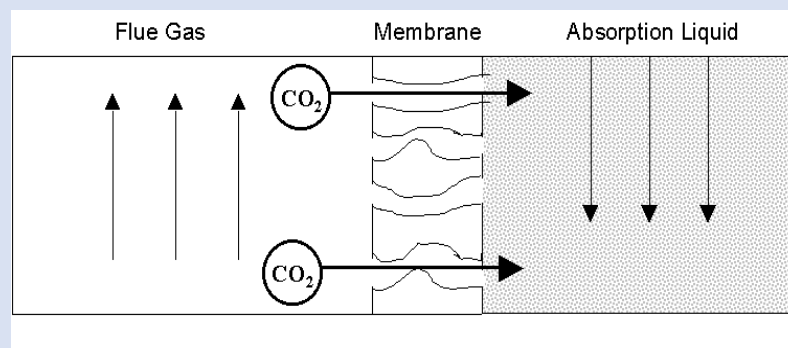

Another way of removing CO₂ from stack gases would be to use the CO₂ to carbonate concrete. In past decades, CO₂-rich flue gases were extensively used to carbonate concrete products, such as pipes and blocks, before they left the factory gate, providing extra strength and resistance to environmental degradation to these products. Co-location of cement production and carbonated-concrete-product production would offer an opportunity to revive this practice.³³ Taiheiyo is researching another technique, using carbon-fixing microorganisms, which involves artificial weathering of waste concrete or other cementitious products (cement made with steel slag, fly ash, etc.) that will react with CO₂ to produce CaCO₃.^{34,35,36} The most advanced versions of this technology utilize the waste material as a substrate for marine microorganisms (e.g., algae) that also consume CO₂ and form CaCO₃. In addition, solar intensifiers and CO₂ injection have been used to accelerate the absorption rate. Although it is unlikely that the rate at which these techniques could sequester CO₂ would come close to the rate at which CO₂ is being produced by cement production processes, they could be used as part of a multi-faceted CO₂ reduction strategy.

Another prospect is the production and incorporation of chemically absorbent materials in cement.³⁷ This relates to ceramic materials – lithium zirconates or lithium silicates -- that can chemically absorb CO₂ at room temperature. Toshiba claims that lithium silicate “absorbs 400 times its own volume of CO₂” and that it “absorbs CO₂ at a rate 30-times faster than lithium zirconate and lithium transition metal oxide predecessors. In a 20% CO₂

gaseous environment at 500°C, 1g of lithium silicate absorbs 62mg of CO₂ in a minute...” This material could potentially reduce kiln emissions, perhaps by being placed inside the kiln or by collecting some portion of the exiting emissions in canisters or other devices.

- **Lower-cost, advanced combustion processes and air pollution control.** Many advanced methods to reduce emissions are under investigation for application at cement plants. For example, the regenerative thermal oxidizer in combination with flue gas desulfurization³⁸ offers a possible solution for controlling cement kiln air emissions of hazardous air pollutants, volatile organic compounds, carbon monoxide, sulfur oxides, and odor. Selective catalytic reduction (SCR), which is more advanced but expensive than selective non-catalytic reduction (SNCR), involves reducing NO_x emissions by chemical reaction with a reducing agent. This has been applied at a number of European kilns, but is not in wide scale use today due to its relatively high cost. Other advanced NO_x emissions techniques are being tested in France and other countries. These technologies offer opportunities to minimize emissions of air pollutants, contributing to the quality of life of surrounding communities. Methods to reduce the cost of high-efficiency pollution control will help foster its use and help the industry aim toward plants with near-zero emissions.

3.2. *Product Pathways Toward Sustainability*

Product innovation pathways that could lead to greater sustainability are described below. Descriptions of additional technologies and more detail on some of those described below may be found in Appendix A.

- **Use of Renewable and Waste Materials in Cement.** As discussed in Section 2, cement companies have been using fly ash, slag from the metals industry, silica fume, incinerator ash, and other wastes to produce blended cements. Use of these materials lowers the amount of clinker needed to produce cement (or concrete), thus lowering energy and limestone use and carbon dioxide emissions. According to Mehta (and others),³⁹ there is a great potential for significantly increasing the use of cementitious and pozzolanic byproducts of industrial activities (power production and metallurgical industries) in cement, which could greatly reduce the amount of new Portland cement capacity and production in the future. In addition, there other renewable materials and wastes that can be used in cement, including:

- Rice husk ash, palm oil fuel ash, and other agricultural wastes
- Components of waste concrete (see box on next page)
- Sludge from paper mills, which has been heated to form metakaolin. Note: metakaolin can be used as an additive to concrete and produces a very impermeable product that is suitable for many uses, including immobilizing wastes for many uses, including immobilizing wastes^{45,46, 47} (see Appendix A)

Use of Agricultural Wastes in Cement

Brazilian researches are developing a method to use rice husk ash to create silica that can be used in blended cement.⁴⁰ This type of blended cement results in cement with lower porosity, increased density and improved resistance to corrosion, increasing strength and life of the concrete.⁴¹ Palm oil fuel ash (see Appendix A) and by-products from sugar cane may yield similar results.⁴² Rice husk ash is not yet available commercially, and estimates of the volumes are uncertain.

- **New pozzolanic additives.** Cement companies could research new pozzolanic additives. For instance, a potential resource that has been scarcely used to date is mixed kaolin-montmorillonite-illite clays. Their thermal activation could result in a range of new pozzolanic admixes.³³

- **More sustainable concrete formulations.** This study focuses on increasing the sustainability of **cement**. Methods to improve the sustainability of **concrete** could be a study in itself. However, it is difficult to discuss sustainable product innovation without some discussion of how the product could be **used** in a more sustainable manner. So, a short discussion of some principal sustainability-oriented innovations in concrete is included in this section. An in-depth analysis of the sustainability of concrete was not undertaken, so the following should be viewed as a small sample within the range of possibilities:
 - The amount of fly ash or other wastes or natural pozzolans in concrete can be increased without the need for high water contents by adding superplasticizers to the concrete mix. Fly ash has been increased to 60% or more using this approach.⁴⁸ Superplasticizers are expensive, however, and research directed toward finding lower-cost alternatives is needed.
 - When high (greater than 39-49%) pozzolanic contents are used, cement may be supplemented by other activators, such as $\text{Ca}(\text{OH})_2$ and gypsum, which have much lower environmental footprints than Portland cement.
 - Wood chips from used construction timber can be incorporated with cement to produce concrete suitable for various construction applications.⁴⁹ This utilizes abundant waste material, decreases use of aggregates, and potentially decreases costs.
 - Recent studies show benefits of using of rubber particles from used tires to replace fine aggregate in Portland cement-based concrete used in roads.⁵⁰ With regard to carbon dioxide emissions, use of tires to replace aggregate in concrete may prove a viable alternative to using tires as fuel in cement kilns, because the carbon in the tires would be sequestered in the concrete instead of being released as CO_2 .
 - Sulfur concrete developed by Taiheiyo is a new type of concrete made from recycled resources. The process applies vibration and pressure to petroleum refining waste and ash from coal-fired power plants to create a dense, acid resistant concrete (see Appendix A).
- **High value products with improved environmental benefits.** A potential way to enhance sustainability is to increase the durability and/or strength of cement-based products. More and more, concrete is becoming a complex material that includes not just ground clinker, pozzolanic admixtures and calcium sulfate, but specialized chemicals including organic molecules and polymers. Some concretes are made to withstand harsh conditions, such as high CO_2 concentrations in geothermal and oil wells, or to contain radioactive wastes. Other concrete formulations increase durability (see “1000-Year Concrete, next page), which potentially decreases the need to replace of older structures, creating less waste for disposal, lower fuel use and emissions associated with clinker production, and less social and economic disruption. This involves designing, specifying, and executing according to specification to ensure longer performance lifetimes for new structures. The extra cost

Concrete Recycling

Several research groups are developing sophisticated methods to separate concrete into components that can be used as aggregates and cement precursors. One method consists of heating concrete in an electrical furnace at a temperature between 650 and 700 degrees C.⁴³ Another promising technology, called Franka-Stein, uses electro-dynamic fragmentation to treat concrete in a powerful electric arc, which separates the electrically weak material boundaries prevalent in concrete.⁴⁴ In addition to making clean aggregate, the Franka-Stein process separates cementitious material that can replace natural raw material in the production of cement. If recycling methods prove cost effective and energy consumption for the separation processes does not prove prohibitive, these technologies may be a strong contributor to increasing sustainability in the cement and concrete industries.

involved is often comparatively slight.³³

“1000-Year Concrete”

Extending the life of structures is one way to reduce lifecycle energy consumption, CO₂ emissions, and other environmental effects of cement, while providing societal benefits. Researchers at University of California, Berkeley, have been analyzing the composition of old buildings (e.g., the Roman structures built from lime-pozzolan mixtures) and have designed fly-ash-based concrete with similar long-lasting qualities. The foundation of a magnificent temple in a remote area on the island of Kaua'i in the Pacific Ocean was built using the “1000-year” formulation, which included very low cement content (106 kg/m³), crushed basalt as the coarse aggregate, sand made from crushed calcareous stone as the fine aggregate, air entraining and water reducing admixtures, and a high volume of fly ash. The construction used innovative water curing techniques, limited modern equipment, and no reinforcing steel. Although this example focuses on a unique setting different from most places concrete is needed in the modern world, other formulations with increased durability that use more up-to-date construction techniques are feasible.

Reference: Mehta and Langley.⁵²

Another way to increase lifetime of structures is to take steps to repair or revitalize them. There are various ways to do this, ranging from simple patching, to applying coatings (see Appendix A), to high technology methods such as osmosis and electrolysis, or realkalization.³³ The more advanced techniques lack independent performance verification and the full evaluation of adverse consequences.

Some concrete formulations result in concretes that are extremely strong; for instance, reactive powder concretes can be made stronger in compression than steel.⁵¹ Use of these ultra-high-performance concretes can improve sustainability because they make it possible to support a given structural load with less cement and aggregate than normal strength concrete. In the current marketplace, the unit price of reactive powder concrete is very high, but its price should not be compared to the price of ordinary concrete; it should be compared to steel on a per tonne basis. In that comparison, concrete would be the lower-cost product.⁵¹ If the market can be conditioned to see things from this functionality-based viewpoint, sustainable cement-based products potentially can be sold at higher prices and margins.

Cement can also be used as an environmental clean up agent (see Appendix A), and additional cement companies interested in sustainability could put effort into inventing additional environmental uses for cement products.

- **Cement with increased reactivity and lower calcium content.** One way of increasing the sustainability of cement is to increase its reactivity so that less clinker is needed to produce the same level of binding. The Energetically Modified Cement (EMC) is a patented process that involves intergrinding a mixture of ordinary Portland cement (OPC) and materials such as fly ash, blast furnace slag, or quartz sand through multiple high-intensity grinding mills (typically vibratory or stirred ball mills). This patented method of grinding imparts increased surface activation of the OPC and the pozzolanic material, improves the reactivity of the OPC as well as the pozzolan, and allows a high percentage of pozzolan to be used without a delay in early strength development. Tests of the resulting product (EMC) have been done by certified laboratories in Europe (with quartz sand) and in the U.S.A. (with fly ash) using 50% Portland cement and 50% quartz sand and 50% fly ash, respectively.^{53,54} A review of these proprietary test results during the course of this project indicates that concrete made from EMC cement performs as well as or better than ordinary Portland

Cement. Comparisons of the early strength development and other properties of concretes using EMC, OPC, or other types of cement will vary depending on the exact formulations.

A facility that uses this grinding approach has been in operation since 1994 in Sweden at a small scale (1 tonne/hour) and has been tested at 10 tonnes/hour. Scaling up the size is achieved by aggregating 10 tonne/hour modules. For instance, a six-module facility (60 tonnes/hour or 400,000-500,000 tonnes per year) is planned.

Although capital and O&M costs would be incurred for a facility that could conduct this additional grinding step, the cost of producing EMC would likely be lower than the cost of OPC because 50% of the raw material in EMC is fly ash or sand, which is currently much less expensive than OPC (see Appendix A for more detail). Use of fly ash and other fillers in concrete can increase durability by improving alkali-silica reactivity, sulphate resistance, gas and water permeability, etc.

Another approach to increasing sustainability involves increasing the belite content of cement. The belite fraction consists of dicalcium silicate (with two molecules of calcium per molecule of silicate), while the alite fraction that predominates in normal Portland cement consists of tricalcium silicate (with three molecules of calcium per molecule of silicate). So, increasing the belite fraction will reduce calcium content, the amount of limestone needed, and hence the carbon emissions associated with cement production. However, belites take longer to attain the same strength as alites. Methods to increase the reactivity of belitic clinker are being investigated by Italcementi.⁵⁵ Tests conducted with the EMC grinding method described above indicate that this technology can increase the reactivity of belitic clinker.

- **Cement-like products produced through new processes.** While clinker is made by calcining calcium carbonate, mineral polymers with cement-like properties can be made from inorganic compounds. Geopolymers, one form of mineral polymers made from inorganic alumino-silicate compounds, were originally developed to create non-flammable material and have subsequently been used in the automobile and aeronautic industries and in certain cement markets (e.g., for waste encapsulation). They are produced at lower temperatures than Portland cement and do not use calcium carbonate, hence the CO₂ emissions are about 80% lower than from Portland cement.⁵⁶ However, a complete energy analysis that includes energy required to produce the inputs to the process might show somewhat different comparative results.

Preparation of Portland Cement Components by PVA Polymerization

The University of Illinois in the United States has been conducting research to co-dissolve nitrate salts and colloidal silica in (poly) vinyl alcohol (PVA), creating a polymer that, when dried and ground, can be calcined at 700 degrees C to form the key components of portland cement. The product is extremely reactive, develops strength quickly during hydration, and offers the prospect of using reinforcement in concrete that usually corrodes with ordinary Portland cement.

Source: Lee et al.⁵⁷

Polymer concrete consists of organic polymers, typically unsaturated polyesters, that bind together inorganic aggregates – essentially replacing the hydraulic binders in ordinary Portland cement with organic polymers. In addition to being used as a structural building product, polymer concrete can be used as an overlay or coatings on ordinary Portland cement concrete to dramatically increase the durability and lifetime. By increasing the lifetime of the concrete, considerable amounts of materials and energy

resources, and associated impacts, can be conserved. Recently, investigators have studied the use of resin obtained from recycled PET bottles (water and carbonated beverage containers). Polymer concrete from recycled-PET-resin is stronger and cheaper than conventional polymer concrete.^{58,59,60} Recycling PET into polymer concrete also aids in waste disposition. (See Appendix A.)

Ceramicrete, a chemically bonded ceramic, is formed by mixing magnesium oxide powder and soluble phosphate powder with water, resulting in a nonporous material with compressive strength higher than that of concrete.⁶¹ (See Appendix A.)

Another very experimental method to produce the components of cement at lower temperatures involves a PVA chemical process⁵⁷ – see box on previous page and Appendix A.

These experimental methods have not been proven in commercial operation and may prove both costly and technically quite complex to produce at the large scale needed for high volumes of cement. However, such lines of research represent potential routes to increased sustainability. Cement companies could investigate some of these products for blending with Portland cement or for niche market uses.

- **Inexpensive Building Products that Use Cement.** Cement plays a critical role in infrastructure development. However, in some developing countries, even a relatively low-cost product such as concrete is beyond the reach of the very bottom stratum of society. Effort directed at finding innovative ways to use of cement could lead to very low-cost building materials that are very inexpensive and that use local materials and labor. Typical products that have traditionally been used in developing countries include:
 - **Rammed earth blocks that use cement and local soil.** The Mountain Institute has developed a building construction system that uses a hydraulic press to produce Stabilized Rammed Earth (SRE) blocks from cement (5%-10%) and local soil (90%-95%) which can be dry-stacked in construction without mortar.⁶² This technology is well suited to support community development and disaster relief in developing countries and remote areas because it is inexpensive and easy to build, use, maintain, and transport.
 - **Cement board made from bamboo and cement.** Cement can be mixed with quick growing organic fibers, like those from bamboo, to create a strong, low-cost building material. It also proves quite durable during earthquakes. The binding system involves filling the joints between the bamboo fibers with cement which improves the strength to the point that, on the basis of its weight, it is better than steel (See Appendix A).

Countries such as India have been actively pursuing such low-cost products for housing and other development needs. Because developing countries will represent a growing portion of construction demand in the future, cement companies could benefit financially by developing innovative products for this market. In addition, pressures on the environment will be lower if poorer grade raw materials can be utilized in applications that do not require the high quality of Portland cement. For example, cement companies could explore use of magnesian limestone, which would result in less waste at quarries, and could work with concrete companies to investigate use of lower grades of aggregate, which may require modifications in cement to suppress adverse alkali reactions.³³

3.3. Management Innovations that Could Foster Sustainability

As discussed in Section 2.6, some cement companies have developed strategies that include new business concepts, such as the waste management business and e-commerce. In

addition, many cement companies are vertically integrated and are formally associated with companies that produce aggregate, make concrete, or conduct other functions directly related to cement. Each company develops a business strategy focused on their unique business goals, their current assets and situation, the competition in their markets, and many other factors. This section provides some examples of management innovations and new business concepts focused on various aspects of sustainability. This is not intended to be a comprehensive set, but these ideas are presented to stimulate thinking about how the drive for sustainability could lead to changes in business strategy that are profitable.

- **Developing new product delivery mechanisms in developing countries.** Developing countries need a wide range of products to support sustainable development, including those that are environmentally sound, less expensive, and easy for people to use. Even if the amount of cement used in these products is lower than might be used in conventional concrete structures, development of these products might open markets for cement that would otherwise go unfilled. However, product delivery would be dependent on a mechanism to sell, deliver and train communities how to use new technologies and on mechanisms to deliver the cement to poor communities. In a case like this, a cement company could partner with an organization that has the core competencies in socio-economic development (e.g., skills in distribution of products in rural areas and in training). Cement companies who entered into such a partnership would be in the best position to sell cement in rural communities. Their cement could be associated with helping communities. Companies in other industries have experienced significant financial success by developing new business concepts geared toward what Hart and Milstein⁶⁴ call the “survival economy” -- the situation most often found in rural villages, urban slums and shanty towns – see box. Although the example presented in the box – denim fabric -- is a product very different from cement, the Ruf and Tuf jeans product and delivery mechanism are conceptually analogous to the SRE blocks and TMI machine described above. Poorer areas should not be seen as a dumping ground for outdated or inferior technologies, but better understanding the needs in these areas can be a stimulus for innovations that lead to better products for these markets. Cement companies that choose to pursue such opportunities may be able to introduce new products in a market with minimal competition that offers “first mover” advantage.
- **Selling structural guarantees.** The text above discussed new concretes that have improved performance, such as better durability or higher levels of strength. As Prof. Aitcin said in his recent article on the future of the cement industry⁵¹ (p. 1358), innovative contractors and building owners may come to realize that what is important is not the cost of one cubic meter of concrete, but the cost of one Mpa or one year of life of a structure. This idea is particularly

Case Study: Meeting Basic Needs of the Survival Economy: Arvind Mills

“Although companies like Levi’s or Lee depend on wealthy consumers who can buy their denim products in large retail stores near urban areas, in India, Arvind Mills has created an entirely new value-delivery system for blue jeans. As the world’s fifth largest denim manufacture, Arvind found Indian domestic denim sales limited because a \$20 to \$40 pair of jeans is neither affordable to the masses nor widely distributed. In direct response, Arvind introduced Ruf and Tuf jeans, a ready-to-make kit of components (denim, zipper, rivets, patch) priced at about \$6. A network of 4,000 tailors, many in small rural towns and villages, distribute the kits extensively. Ruf and Tuf jeans are now the largest selling jeans in India, easily surpassing Levi’s and other brand names from the United States and Europe.”⁶⁴ A similar model could be used for cement/ concrete construction. For example, cement distributed to a large network of local manufactures could be used to produce sustainable building blocks or other cement-based products using local waste materials, soil, etc.

relevant to “BOOT” projects, which are becoming more commonly used, in which an architectural and engineering (A&E) firm or developer builds, owns, operates, and eventually transfers the asset to the local authorities. In such projects, the developer must feel confident that the asset will last the full tenure of the firm’s ownership, and once it is transferred, the new owner may demand guarantees that the asset will be reliable for an extended amount of time, so a guarantee may be needed. Certain segments of the cement industry, notably the concrete roof tile industry, are accustomed to giving long guarantees, in some cases 40-60 years, for their products; thus precedent exists.³³ To serve this type of market, concrete producers will have to know how to use a wide variety of cements, admixtures, and high-tech formulations in order to guarantee longevity. The price of concrete that can be guaranteed for long life will be higher than the normal concrete used today. Cement companies that can provide cement products that add to the increased value will share in some of the profit (and also take some risk that the product will fail to live up to the guarantee). The share of the value-added would be larger for those cement companies who have diversified into admixtures, concrete, or the construction industry.

- **Combined cement, energy and CO₂ management companies.** Just as some cement companies are beginning to consider themselves industrial ecology or waste management companies today, some cement companies in the future might begin to think of themselves as energy and carbon management companies. The potential relationship between electricity and cement production was explored in Section 3.1. If we take that concept a few steps further, we can envision a company that makes profit from one or more of the following activities: making electricity (e.g., in coal-fired plants and fuel cells); producing and selling hydrogen (using some of it in the fuel cells); capturing and selling carbon, e.g., to natural gas and oil companies that inject it into wells for production; selling carbon management services to other industries; and making cement (e.g., using ash from the coal-fired boiler and other sources). The transformation of a cement company into an integrated company dealing in energy, carbon management and cement would require a complete business upheaval, including technical and business competencies very different from those held by today’s cement companies. This is not necessarily a vision of the future that cement companies are interested in pursuing. However, it might be a vision innovative energy companies are interested in pursuing, and could present a potential disruption in the cement market – a new entrant with a new technology. Or, this prospect could offer an opportunity for closer collaboration between cement and energy companies.
- **Waste management and resource extraction companies.** Cement companies in the future could move into the business of treating hazardous substances and transforming them into safe, useful materials. This could involve use of a wider range of alternative fuels and raw materials and extracting valuable, saleable materials from these wastes. For example, instead of simply “manufacturing” cement, Taiheiyo aims to conduct the process of “eco-fracturing” whereby valuable materials are recovered during the production of cement. This is already happening in Taiheiyo’s Ecocement plant where chlorides of lead, copper, and zinc are collected and sent for further refining.

4. Creating Sustainability-Focused Innovation: How Can a Company Get There?

The previous section presented many options for pathways toward sustainability. The question now becomes, how does a company choose which pathways to pursue? Some of the pathways are riskier than others, from financial, technical and environmental/social perspectives. Because each cement company has a unique blend of culture, beliefs, assets and business/financial situation, no single pathway can be designed to fit all cement companies. The basic steps cement companies should take to decide on options include:

- **Ensure that many sustainability-focused options for the future are being considered.** Cement companies should be constantly seeking innovative, sustainability-focused opportunities that can simultaneously bring in additional revenues, lower costs, increase product value, or otherwise increase profitability.
- **Examine the options from a holistic environmental and societal perspective.** When considering the use of alternative materials or fuels in cement production or developing new products, companies should consider the full range of environmental and quality-of-life effects of all the alternative materials. Tradeoffs will have to be considered; lifecycle assessment techniques and tools to estimate the value to society of various innovations could be employed. Some products or process changes may reduce one environmental or societal problem, but create others. The full impact of changes should be fully evaluated.
- **Consider stakeholders perspectives.** As discussed in [Substudy 3 \(Business Case\)](#), an important step in the process is to identify internal (enterprise) and external stakeholders of any business decision.
- **Consider financial risks and benefits, including the risks and benefits of not innovating.** It is important that the risks and benefits of **not** innovating be factored into the analysis. Competitors, suppliers, customers and new entrants to the industry (e.g., developers of “disruptive” technologies) promoting sustainable products/processes could steal market share or value from established cement companies. On the other hand, there are risks associated with innovation, and hence potential benefits of not innovating. Companies will have different tolerances for risk, and different philosophies about the level of innovation.

Companies can choose whether to face the potential rewards and risks associated with being an innovation leader, or to simply keep up with the latest innovations, adopting only those innovations that appear to be most successful. In either situation, companies will have to put in place mechanisms (“enablers”) to help them achieve their sustainability-focused goals and make progress on their chosen pathways. Section 2.3 discussed some of the practices cement companies have already put in place to assist in their innovation and sustainability efforts, and this section provides a more generic set of recommendations about building a sustainability-focused innovation capacity within an organization. [Substudy 4 \(Alignment\)](#) also discusses related topics.

Although promoting and implementing innovation is one of the greatest challenges confronting organizations today, top-level representatives of most companies report that they do not feel that their company is particularly good at doing this.¹⁰ As a result, the literature has increasingly explored factors that promote or hinder an organization’s capacity to innovate.

If a company can develop a stronger innovation capability/capacity, it will better support the success of the innovation process.⁶³ The work of Hamel and many other authors contributed to the recommendations in this section. Although their advice does not apply specifically to *sustainability-oriented* innovation or to cement companies, it has been tailored to focus on

sustainability-focused innovation in the cement industry. Recommended actions for fostering sustainability-oriented innovation are as follows:

1. **Solicit innovation ideas:** Companies should explain sustainability concepts to employees and provide a mechanism for employees to offer suggestions for new product, process and business concept ideas. The exact mechanism by which cement companies solicit ideas must be designed by each company to fit within its culture. Some possible mechanisms include: suggestion boxes (a place where employees can submit ideas, either electronically or in writing), employee focus groups, assigning business development officers to serve as advisors to employees with innovative ideas, putting a “sustainability” or “innovation” button on the companies internal home page to solicit ideas, and holding employee meetings with managers on the topic of sustainability-focused innovation. In addition, the company should fully educate employees about the business challenges facing the company and why both innovation and sustainability are important.
2. **Encourage team thinking.** Innovation is often the work of several people working together. To foster this, cement companies should facilitate cross-functional interactions, job rotation and employee networks (such as electronic and face-to-face opportunities to ask for advice, provide assistance, participate in dialogues, share lessons learned, etc.) and support mentoring and other relationships between employees, senior staff, and management.
3. **Reward and recognize staff initiative toward sustainability-oriented innovation.** Rewards can be offered to provide incentives for creativity and innovation related to sustainability. Rewards should be tailored for different categories of employees, and can involve financial benefits (raises, bonuses) or other types of benefits, such as free time to work on an innovation or ability to attend conferences. Conversely, barriers to innovation and sustainability should be better understood.^{***} The company could provide mechanisms for employees to offer suggestions about how sustainability and innovation could be more strongly supported, and to do an assessment of the managerial and institutionalized disincentives for sustainability-focused innovation.
4. **Conduct competitive intelligence and knowledge management.** Cement companies interested in sustainability-focused innovation should continuously seek information about scientific, technological and managerial innovations occurring both inside and outside the company. This can involve looking beyond the cement production field for technologies in other industries that can be applied to cement production. The effort should involve organized systems for technical intelligence and environmental scanning, surveying customer needs, encouraging networking and formation of “communities of practice” within the company to share information and lessons learned, enterprise level knowledge systems, and corporate-level problem identification and problem solving processes. A key to success in this area is information technology – intranets, email, newsgroups, instant messaging, and other similar systems.
5. **Manage the innovation stream.** Innovation “projects” are often more difficult than typical engineering or manufacturing projects. There are two critical phases of innovation projects which must be recognized and treated differently: the “fuzzy front-end” (Phase I) activities that involve conceptualizing, formulating, and analyzing ideas, and project management (Phase II) activities, which involve more definitive research tasks and resemble projects in general, including product design, piloting, production, and early marketing.⁶⁵ Strategies and techniques for speeding up the early Phase I activities, which presently account for half the innovation project cycle time, are just now evolving. One approach might be to dedicate a

^{***} People who have successfully developed revolutionary new products within established companies often comment that they succeeded **despite** the system⁶³ (p. 292). For example, see case studies of the innovators who developed the Sony Playstation, IBM's Global Services business, and the renewable energy focus at Royal Dutch Shell.) Companies truly interested in fostering sustainability-oriented must better understand the internal management system barriers to innovation. The barriers could be embedded in processes and systems related to compensation, product development, strategic planning capital budgeting, succession planning, training, etc.

small core group to the Phase I effort and providing access to many experts. The group might be most successful if it is isolated off-site to discourage distractions and promote intensity, and if it has a history of working together effectively (or can develop a high degree of teamwork). Processes to manage Phase II activities are usually well established in cement companies that have an R&D focus. Managing the entire stream of innovation involves soliciting ideas from employees (see item 1 above), selecting promising ideas for experimentation, managing the innovation development process for serious ideas and diffusing innovation, once developed. Companies can set up experimentation projects to assess the true value of the selected innovation ideas. For those that look most promising, it may be most effective to create ad-hoc separate organization to further develop them.^{†††} The culmination of innovation is to transfer the innovation to those who will exploit it through successful implementation and, as needed, promoting its adoption into organizational practice and/or individual work styles.

6. **Form partnerships directed at sustainability-focused innovation.** Partnerships to promote collaborative research and development to identify useful product and service innovations, process innovations, and strategy innovations will become increasingly important. One of the key types of partnerships is with suppliers. It may be especially important to form broad-based partnerships and associations across the cement industry as a whole or between groups of cement companies (with additional partners as appropriate). Such partnerships would best be directed toward pre-competitive research on both sustainable products and processes and could be conducted within the context of a formalized association or *institute*. It is also extremely useful to develop relationships with community organizations, public and private infrastructure organizations, regulators, competitors and other industries.

^{†††} Many organizations find it difficult to support the existing business and at the same time foster radical or disruptive innovations, because the approaches needed are very different. Cement companies could create separate enterprises (entrepreneurships) within the organization that focus on particular sustainability-focused innovations. These separate organizations should integrate with the main part of the organization with regard to strategy, production, marketing, customers, and stakeholders, while maintaining a distinction culture, processes, and systems geared to promote innovation. In the case of some potentially disruptive innovations, the company may want to form a spin-off company in which the cement company holds equity.

5. Recommendations

The research conducted for this report and documented in the previous sections led to the recommendations below, which are grouped into two categories: (1) those involving more widespread application of past innovations, and (2) those related to developing new products, processes and management innovations.

1. **Foster more widespread application of past innovations and best practices (described in Section 2):**
 - **Continuously improve existing plants and quarries** by identifying and using best practices during siting, planning, and operation to assess, monitor and manage development and reduce impacts. Apply technologies that increase energy efficiency and improve pollution control. Set corporate standards for performance of existing plants. Develop and apply methods to evaluate options for lowering energy consumption and environmental impacts so as to choose cost-effective options to meet the corporate standards. Develop, disseminate, and adopt innovative siting and land use planning methods that consider cultural sensitivities and biodiversity.
 - **Design new plants to incorporate state-of-the-art technology** such that they have a low level of public disturbance, decreased impact on natural systems, and near-zero emissions. For instance, use advanced geo-statistical techniques, linear extraction and semi-open cut mining [for quarrying], as well as highly energy-efficient process equipment, process control, alternative energy forms, noise reduction techniques, water management and recycling, air pollution monitoring, and advanced air pollution control devices (such as pulse-jet filters and SNCR).
 - **Find productive, environmentally-sound, and socially-acceptable uses for depleted quarries and retired plants.** Restore depleted quarries to natural habitats. Convert retired cement plants and equipment to alternative uses could extend the value of these assets. Plan for these end-of-lifecycle uses.
 - **Encourage increased use of blended/composite cement** to reduce the amount of limestone calcined and the level of CO₂ emissions. Produce and sell blended and composite cements by developing business relationships with suppliers of a wide range of blending materials (e.g., fly ash, slag, natural pozzolans, silica fume, and agricultural byproducts).
2. **Increase emphasis on developing product, process and management innovations that make stepwise improvements in environmental and societal aspects of cement production and use, while maintaining the viability of the cement industry.**
 - **Increase cement company role in cement process design.** Help equipment suppliers set an R&D agenda for SD-oriented cement process change. Provide financial support for SD-oriented process R&D, including work at universities and by other parties outside cement companies. Work cooperatively with other companies, suppliers, and universities on long-term projects leading to dramatically improved cement production processes, emphasizing low emissions (including CO₂ emissions).
 - **Develop or support development of (e.g., by universities and outside parties) new, cement-based products specifically aimed at environmental and social improvements.** For example, create or support creation of novel products for developing economies that safely meet their construction needs in a cost-effective manner, and develop cement products that can be used to ameliorate environmental problems. And, develop high-value products that help ameliorate environmental clean-up problems, reduce CO₂ emissions, or have other environmental or social benefits. To accomplish this, include environmental or societal benefit criteria in R&D project selection and specifically seek out

sustainable product ideas. Experiment with marketing new SD products within niche markets to gain more experience with such products and to break down barriers in the companies and in the marketplace.

- **Encourage creative SD thinking among employees by providing support, incentives and rewards for SD innovation.** For example: Use knowledge management systems and cross-company meetings to share innovative ideas. Expand personnel reward programs to include rewards for SD innovation. Solicit SD innovation idea. Encourage teamwork. Effectively manage the innovation stream.
- **Conduct or support research to characterize the risks and benefits of innovations,** such as use of alternative fuels and raw materials. Conduct research on health and environmental impacts of AFR and other innovations. Develop/apply lifecycle analysis methods and methods to evaluate societal costs and benefits of innovation.
- **Create the *Sustainable Development Institute of Cement and Concrete*** to promote worldwide progress toward sustainable production and use of cement and concrete. Leverage resources with other member institutions (cement and concrete companies, suppliers, universities and other research organizations, cement associations, government institutions, economic development organizations) to conduct early-stage research to develop and assess new process and product technologies. Work collaboratively to lower the risk and hasten the development of breakthrough innovations.

6. References

1. Holliday, C. and Pepper, J. Sustainability through the Market: Seven Keys to Success. Geneva: World Business Council for Sustainable Development, 2001.
2. Schumpeter, J. The Theory of Economic Development. Cambridge: Harvard University Press, 1934.
3. Schumpeter, J. Capitalism, Socialism and Democracy. New York: Harper Torchbooks, 1942.
4. Von Weiszacker, E.U., A.B. Lovins, and L.H. and Lovins, The Factor Four. London: Earthscan. 1997.
5. Wuupertal Institute. The International Factor 10 Club's Statement to Government and Business Leaders: A Tenfold Leap in Energy and Resource Efficiency. 1997.
6. Best Available Techniques for the Cement Industry. Brussels: CEMBUREAU, 1999.
7. Meadows, D.H. et al., Beyond the Limits Post Mills, Vermont: Chelsea Green Publishing, 1992.
8. Nriagu, J.O. "Global Metal Pollution," Environment, 32 (1990) 7-32.
9. The Reduction of Greenhouse Gas Emissions from the Cement Industry. PH3/7. Paris: International Energy Agency, 1999.
10. Jonash. R.S. and Sommerlatte. T. The Innovation Premium. Perseus Books, Reading, Pennsylvania, 1999.
11. Christensen, C.M. The Innovator's Dilemma. Boston: Harvard Business School Press, 1999.
12. Tibbs, H. Sustainability. Emeryville, California: Global Business Network, 1999.
13. Porter, M. Competitiveness of Nations, Boston: Harvard Business School Press, 1994.
14. Markides, C. C. All the Right Moves. Boston: Harvard Business School Press, 2000.
15. Introduction to Environmental Technologies. Tokyo: Taiheiyo Cement Corporation, (corporate brochure).
16. EMAS Environmental Statement. Ruderdorf: Ruderdorfer Zement GmbH, 2000.
17. www.grancem.com
18. Environmental Report 1999. Lisbon: Cimpor, 2000.
19. Rocha, P. Personal communication. Cimpor, Lisbon, Portugal.
20. Dumrongsak, C. Personal communication. Siam Cement Industry, Bangkok, Thailand.
21. Picard, M., Personal communication, Lafarge, Paris.
22. Cassar, Pimpinelli, and Pepe, "Photocatalytic Properties of Special Cements," Proceedings of the 7th European Conference on Advanced Materials and Processes "EUROMAT" held in Rimini, Italy, June 10-14, 2001.
23. Helft, D. "Cemex Attempts to Cement Its Future." Industry Standard, 3.45, (2000): 134.
24. Kahn, R. and P. Hill. "An Uncommon Use: County Sanitation Districts of Los Angeles County Send Biosolids to Cement Plant to Reduce Manufacturing Emission." Water Environment and Technology May 1998: 44-49.
25. Imhof, A. "Solar Cement Plants." ZKG International 53.8 (2000): 448-56.

26. Imhof, A. "Calcination of Limestone in a Solar Reactor." ZKG International 53.9 (2000): 504-09.
27. Martin, N., E. Worell, and L. Price, Energy Efficiency and Carbon Dioxide Emissions Reduction Opportunities in the U.S. Cement Industry, Berkeley, California: Ernst Orlando Lawrence Berkeley National Laboratory, 1999.
28. Glasser, F.P., "Production and properties of cements made by plasma fusion," Cement and Concrete Research 5, (1975): 51-61.
29. Ceriaf, M., Rocha J. Cavalcante, and J Pera. "Pozzolanic properties of pulverized coal combustion bottom ash." Cement Concrete Res. 29 (1999): 1387-91.
30. Webb, S. "Cement kiln cooks with gas." Waste Age 31.1 (2001): 42.
31. Put, B. and C. Doerksen. "Gold in Fly Ash." Energy (Spring 2000): 25-28.
32. Falk-Pedersen, O., H. Dannstrom, M.Gronvold, D. Stuksrud, and O. Ronning, "Gas Treatment Using Membrane Gas/Liquid Contactors," in: Williams, D.J, R.A. Durie, P. McMullan, C.A. J. Paulson and A.Y. Smith (Ed.), Greenhouse Gas Control Technologies, Proceedings of the Fifth International Conference on Greenhouse Gas Control Technologies, CISRO Publishing, Collingwood, Australia, pp. 115-119.
33. Glasser, F. P., Personal communication, University of Aberdeen, United Kingdom.
34. Yamazaki T et al. "CO₂ removal by photosynthesis and calcification using microalgae." Transactions of the Materials Research Society of Japan 18A (1994): 357-60.
35. Takano, H and Matsunaga T. "CO₂ Fixation by Artificial Weathering of Waste Concrete and Coccolithophore Algae Cultures." Energy Conversion and Management 36 (1995): 697-700.
36. Isoo, T., Takahashi T, and Fukuhara K. "Using Carbonated Steelmaking Slag Blocks to Help Reduce CO₂." American Ceramic Society Bulletin 80.1 (2001): 73-75.
37. Toshiba, Press Release "Toshiba Group Continues Progress in Promising Method of CO₂ Absorption" available at "http://www.toshiba.co.jp/about/press/2001_04/pr1901.htm". April 19, 2001.
38. Pennington, R. L. "Can a Modular Kiln Air Emission Control System Help the Cement Industry Meet Existing and Future MACT Regulations?" Rock Products Cement Americas (Nov. 1999): 30-36.
39. Mehta, P. K., "Concrete Technology for Sustainable Development," Concrete International, (November, 1999): pp.47-53.
40. Reuters. "Brazil Researchers Find Rice Makes Nice Cement." Reuters News Service 9 Nov. 2000.
41. Malhotra, V.M., "Making Concrete "Greener" with Fly Ash," Concrete International, (May 1999).
42. Dubach, B. Interview with Barbara Dubach, Holcim (then Holderbank) conducted by Gretchen Hund, Battelle, 7 November, 2000.
43. Van Loo, W. "Closing the Concrete loop—from reuse to recycling." In: Sustainable Construction: Use of recycled concrete aggregate, Proceedings of the International Symposium of the University of Dundee, held in London, UK, 11-12 November, 1998, 83-97.
44. Hoppe, Peter and Uwe Schweike, "Monster Mash" Demolition and Recycling International, (March-April, 2001): 13-14.

45. Pera, J. and Ambroise J. "Pozzolanic Properties of Metakaolin Obtained From Paper Sludge." Ed.V.M. Malhotra. Fly Ash, Silica Fume, Slag and Natural Pozzolans. Farmington Hills, Michigan: American Concrete Institute, 1998. 1007-1020.
46. Pera, J, Bonnin E, and Chabannet M. "Immobilization of Wastes by Metakaolin-Blended Cements." Ed. V.M. Malhotra. Fly Ash, Silica Fume, Slag and Natural Pozzolans. Farmington Hills, Michigan: American Concrete Institute, 1998. 997-1006.
47. Hussin, M.W. and A.S. M. Abdul Awal, "Influence of Palm Oil Fuel Ash on Sulfate Resistance of Mortar and Concrete," Ed. V.M. Malhotra, Fly Ash, Silica Fume, Slag and Natural Pozzolans in Concrete, American Concrete Institute, 1998.
48. Kawaguchi, Nobuhiro, Kiyoshi Kohno, and Masakazu Mita. "Influences of Superplasticizer, Mixing Time, Mixing Temperature and Cement Content on High-Volume Fly Ash Concrete" Material Science Research International 2.4 (2001): 242. available at <http://zairyo.jsms.or.jp/msri>
49. Kasai, Y., M. Kawamura, and J.-D. Zhou. "Study on Wood Chip Concrete With Used Timber." Ed. Malhotra. Michigan: American Concrete Institute, 1998. 905-28.
50. Goulias, D.G. and Ali, A.-H., Evaluation of Rubber-Filled Concrete and Correlation Between Destructive and Non-destructive Testing Results," Cement, Concrete, and Aggregates, GCAGDP, Vol 20, No. 1, 1998, pp. 140-144.
51. Aitcin, Pierre Claude, "Cements of yesterday and today, Concrete of tomorrow," Cement and Concrete Research 30 (2000), pp. 1349-1359.
52. Mehta, P. K. and Langley, W.S., "Monolith Foundation: Built to Last 1000 Years," Concrete International, July 2000.
53. SINTEF, Memo: "EMC Binders, Brief Outline of Test Results" prepared by Erik J Sellevold, SINTEF Civil and Environmental Engineering, Trondheim, Norway, available for review upon request from Atle Lygren, EMC DEVELOPMENT AB, Chalet BALYBY, CH-1936, Verbier, Switzerland, Telephone: 011 41 277753860, email: atlee@lygren.com
54. ISG Resources, Inc., "Technical Evaluation of Energetically Modified Cement (EMC)," confidential document available for review upon request from Atle Lygren, EMC DEVELOPMENT AB, Chalet BALYBY, CH-1936, Verbier, Switzerland, Telephone: 011 41 277753860, email: atlee@lygren.com
55. Cassar, L., personal communication, Italcementi, Bergamo, Italy.
56. Davidovits, Geopolymer website: <http://www.geopolymer.org>
57. Lee, S. J., E. A. Benson, and W. A. Kriven. "Preparation of Portland Cement Components by Poly(vinyl alcohol) Solution Polymerization." Journal of American Ceramic Society 82.8 (1999): 2049-55.
58. Rebeiz, K. S. and D. W. Fowler. "Shear and Flexure Behavior of Reinforced Polymer Concrete Made With Recycled Plastic Wastes." Properties and Uses of Polymers in Concrete. Farmington Hills, Michigan: American Concrete Institute, 1996: 61-78.
59. Rebeiz, K. S. and D. W. Fowler. "Strength Properties of Polymer Concrete Made With Resins Based on Recycled Plastic Waste." Properties and Uses of Polymers in Concrete. Farmington Hills, Michigan: American Concrete Institute, 1996: 79-91.
60. Dimmick, F. E., Sr. "15-Year Tracking Study: Comparing Epoxy Polymer Concrete to Portland Cement Concrete Applied on Slab-on-Grade and Bridge Decks." Ed. J.J.Fontana, A.O.Kaeding, and P.D.Krauss. Properties and Uses of Polymers in Concrete. Farmington Hills, Michigan: American Concrete Institute, 1996. 211-31.

61. <http://www.techtransfer.anl.gov/techtour/ceramicrete.html> Chemically Bonded Ceramic. Argonne National Laboratory.
62. Pratt, J. Personal communication. The Mountain Institute, Harrisonburg, Virginia.
63. Hamel, G. Leading the Revolution, Boston: Harvard Business School Press, 2000.
64. Hart, Stuart L. and Mark B. Milstein, "Global Sustainability and the Creative Destruction of Industries" Sloan Management Review 41.1, Boston: Massachusetts Institute of Technology, (Fall 1999): 23-33.
65. Bacon, G., S. Bechman, D. Mowery, and D. Wilson. "Managing Product Definition in Hi Tech Industries." California Management Review 36(Spring): 32-56.

Appendix A

Innovation Examples – Short Case Studies

This appendix describes examples of sustainability-oriented innovations found in the literature or through interviews with cement company executives and other research groups outside the cement industry. (Note that some of these have been briefly highlighted in the main body of the report.) The examples illustrate ways the cement industry can reduce the environmental impacts of cement production or products, and make contributions to society. The examples include process, product and managerial/policy innovations. Some of the concepts presented are not new; some have been under development for many years. Some are commercially available. Others are in experimental stages and have not been fully tested. A few of the examples come from other industries, not cement, but could be applicable to the cement industry. Given the focus of this report on moving the cement industry toward sustainability, re-examination, adaptation, or further consideration of some of these technologies may be appropriate. Some of the technologies described here might present a threat of “disruptive innovation” to the mainstream cement industry (see the end of Section 1.1. in the main text). **The examples are not meant to represent the best or only solutions to sustainability in the cement industry, but to illustrate the kinds of things cement companies can explore in search of sustainable pathways for the future.**

The scope of the research conducted for this report did **not** include a full evaluation of each of the technologies described. To fully evaluate and compare the environmental, social and economic benefits and costs of various technologies, a full range of impacts over the technologies’ lifecycles should be compared. There are often tradeoffs, and companies must weigh the positive and negative aspects in all three dimensions – environment, social and economic. This type of evaluation was not conducted during the course of this study, but we recommend that cement companies take this comprehensive, full lifecycle perspective when considering their investment and research options.

The appendix consists of a series of tables that are organized using the three categories of innovation - process, product, and management - presented in the main body of report. The main body of the report also discusses eight issues – resource productivity, climate protection, emission reduction, ecological stewardship, employee well being, community well being, regional development and shareholder value creation. The issues most applicable to each innovation are noted. The tables include:

- Table A.1 – Process Innovations
- Table A.2 – Product Innovations
- Table A.3 – Management Innovations

The left-hand columns of the tables contain basic information about each example: the applicable section of the main report that discussed the topic; the company that developed or installed the innovation and the location of the installation (if applicable); the principal sustainability issue(s), the references used as sources of information; and the stage of development. (Note the full references are at the end of the appendix.) The right-hand columns provide a brief description of the innovations.

ERRATUM: Page A-12, left column “Commercial scale plant (60 tonnes/hr or 400,000 tonnes/annum using six 10 tonne/hr units) producing EMC cement containing at least 50% fly ash is planned (construction expected to begin in 2002).”

Table A.1. Process Innovations

Basic Information	Description
<p data-bbox="224 327 553 415">INNOVATIVE QUARRYING TECHNIQUE: SEMI-OPEN CUT MINING</p> <p data-bbox="224 457 521 489">Applicable Section: 2.3</p> <p data-bbox="224 531 500 562">Company/Location: Siam Cement Industry, Lampang Plant</p> <p data-bbox="224 667 594 758">Applicable Issues: Ecological Stewardship, Community Well- Being</p> <p data-bbox="224 800 594 957">References: Personal communication with Cholathorn Dumrongsak, Siam Cement Industry, Bangkok, Thailand</p> <p data-bbox="224 999 529 1031">World Cement, <i>Dec 1997</i></p> <p data-bbox="224 1073 516 1129">Stage of Development: Currently available</p> <p data-bbox="224 1171 553 1293">For more information about Siam Cement Industry Lampang project, see Case Study 1 (Appendix B)</p>	<p data-bbox="630 327 1369 1234">Siam Cement located a new plant in Lampang, Thailand, at the center of an agricultural area. The company wished to preserve the natural landscape as much as possible and minimize environmental impacts. To meet this goal, the company designed an innovative method of quarrying, called “semi-open cut mining.” This quarrying technique is a combination of the two traditional methods known as open pit mining and open cut mining. This method can be compared to the scooping out of a melon in which one leaves the outer skin intact. Siam Cement believes that the public cares more and more about health and preservation of nature, and that businesses, particularly large companies, affect communities and the environment and must pay attention to the concerns of the public. Therefore, Siam Cement developed a policy about environmental protection that includes consideration of environmental preservation in the planning phase of new projects. During the planning of a new plant in Lampang, the subsidiary Siam Cement Lampang Company (SLP) considered various environmental aspects that influenced the technical layout of the plant. The Lampang plant was to be situated in a region almost entirely devoted to agriculture, so the company wished to design it in a way that would fit in with the landscape and be environmentally friendly in its operation. The company desired to minimize environmental effects (dust, noise, etc.) from all quarry activities and preserve the public’s view of the existing landscape. Enforcement of regulations such as those from the Environmental Policy and Planning Authority and the Quarrying Proposal Requirements of the Mineral Resource Department were also taken into consideration.</p> <p data-bbox="630 1283 1369 1755">The SLP Quarry Department developed an innovative method called “semi-open cut mining,” the objective of which is to preserve the appearance of the mountain, restrict explosions and transportation to the quarry area only, minimize dust and noise, and continuously reclaim exposed areas using vegetation. This quarrying technique is a combination of the two traditional methods known as open pit mining and open cut mining. The project was designed and implemented by staff members within Siam Cement. The development procedure begins by cutting from small hills to create a flat level between the mountains. (See Appendix B.1 for more information.) The mining operation occurs in the exposed area, and the level of the mining is adjusted downward as the limestone is removed. This creates an effect that looks like the rows of seats in a sports stadium inside the quarry. On the outside, the outer inclined shell of the mountain remains intact.</p>

Table A.1. Process Innovations	
Basic Information	Description
<p>Innovative Alternative Fuel: Profuel</p> <p>Applicable Section: 2.3</p> <p>Company/Location: Castle Cement, United Kingdom</p> <p>Applicable Issues: Resource Productivity, Climate Protection, Emission Reduction, Ecological Stewardship, Community Well Being</p> <p>Reference: <i>World Cement</i>, Sept 2000.</p> <p>Status of Development: Commercially available</p>	<p>Profuel is made from paper that cannot be recycled, low chlorine plastics and off-cuts from nappy and carpet manufacture. It is being used with other alternative fuels as a replacement for coal. Use of this fuel decreases landfill disposal and wastes/pollution from incineration. It also results in lower emissions, compared to kilns consuming coal alone.</p> <p>The cement company is working with environmental agency to ensure compliance.</p>
<p>Innovative Kiln Technology: Solar Calcination of Lime</p> <p>Applicable Section: 3.1</p> <p>Company/Location: Paul Scherrer Institute, Villigen, Switzerland.</p> <p>Applicable Issues: Resource Productivity, Climate Protection, Emission Reduction</p> <p>References: Imhof 2000, a & b.</p> <p>Status of Development: Experimental; not available commercially partially due to cost issues.</p>	<p>The Paul Scherrer Institute (Switzerland) has studied the technical and economic feasibility of calcining lime using solar radiation as the heating source. A system consisting of solar collectors (heliotropes) and a special pre-calciner must be added to the calciner stack. The technology is only applicable to areas receiving sufficient solar radiation. Up to 85% of the calcination could be performed using the solar calciner, which would lead to roughly a 20% energy saving. Based on projections of market needs and assuming that 10% of needed production capacity can be obtained from plants utilizing solar radiation, the author concluded that ten kilns utilizing solar radiation could be feasible for operation in certain parts of the world by 2010. These plants, however, would only be economically feasible if carbon taxes were imposed. Compared to traditional kilns, solar kilns have lower CO₂ and air pollutant emission and lower consumption of fossil fuels.</p> <p>A 60 kWh calciner has been built and operated at The Paul Scherrer Institute.</p>

Table A.1. Process Innovations	
Basic Information	Description
<p>Innovative Pollution Control Technology: Biosolids Injection</p> <p>Applicable Section: 2.3</p> <p>Company/Location: Mitsubishi Cement Corp., Southdown Cement, Riverside Cement. Demonstrated at Mitsubishi Cement Corp., Cushenbury plant, Lucerne Valley, California in conjunction with Sanitation Districts of Los Angeles County, California, USA the Mojave Desert Air Quality Management District and the California State Department of Trade and Commerce.</p> <p>Applicable Issues: Emission Reduction, Ecological Stewardship, Community Well Being</p> <p>References: Kahn and Hill, 1998.</p> <p>Stage of Development: Commercially available</p>	<p>BioSolids Injection Technology consists of injecting biosolids into cement kiln exhaust gases for a cost-effective reduction of NO_x emissions and as a means to dispose of biosolids. When the biosolids are injected into the exhaust gases, the resulting reaction between ammonia, oxygen, and NO_x generates nitrogen and water. The remaining biosolids combust in the kiln, and the process can be tailored so that the additional fuel required for the process is offset by the thermal value of the biosolids. The process also helps dispose of biosolids waste.</p> <p>The three cement companies, the Air Quality Management District, and the State of California formed a consortium, the Cement Industry Environmental Consortium (CIEC), to study NO_x reduction technologies. A demonstration project was established at one of the company's plants. Phase I of the demonstration project was designed to prove the principle of the use of biosolids to reduce NO_x emissions. Phase II of the demonstration included detailed measurement of emissions and optimizing the process. The process is now licensed to MSR Solutions LLC. NO_x reductions of between 40-50% can be expected at a lower cost than with the use of other methods. In addition, the emissions of numerous other hazardous air pollutants are decreased, whereas only a few are increased (Kahn and Hill, 1998). No effect on productivity has been observed.</p>

Table A.1. Process Innovations

Basic Information	Description
<p>Innovative Alternative Process to Produce Clinker: Production of Clinker in Coal-Fired Power Plants</p> <p>Applicable Section: 3.1</p> <p>Company/Location: Involved parties include: The Chinese Academy of Science, CANMET Energy Technology Center (CETC), Ontario Power Generation (OPG), Global New Energy Inc. (GNE) and Lafarge Beijing Cement Ltd. The technology is being demonstrated at Mengzhuang power plant, a full scale commercially operating plant, in Xinxiang, Henan Province, where the technology has operated successfully since October 1998 (and according to CANMET, “several” other power plants in China) and at CANMET’s 0.3 MW_{th} pilot plant.</p> <p>Applicable Issues: Resource Productivity, Climate Protection, Emission Reduction, Ecological Stewardship</p> <p>References: Put and Doerksen (2000); CANMET Energy Technology Center, unpublished report</p> <p>Stage of Development: Demonstration plants operating</p>	<p>This innovation involves the co-production of electricity and a material similar in composition and behavior to Portland Cement. This is carried out in conventional coal-fired power plants. Reportedly, this technique has been studied in China for about 30 years. The technique consists of co-firing coal and an ash-modifying compound in a conventional coal-fired power plant furnace. The resulting calcium-rich, belite material can be directly substituted for clinker. In addition, the process captures sulfur compounds generated by the coal combustion and therefore reduces SO_x emissions from the power plant. The process does not greatly affect the combustion efficiency of the power plant. Due to the co-generation of power during the process, the cost of clinker manufactured using this method may be lower than current costs. Co-generation of power and clinker also reduces the total combined greenhouse gas emissions. Labor and equipment costs are also reduced due to co-generation.</p> <p>According to Put and Doerksen, “The research began with a focus on improving inefficient industrial processes that consume nonrenewable resources and create serious environmental pollution.” The research was conducted jointly by electric utilities and cement companies in China and has considered various aspects of the combustion, aerodynamics, transport behavior, and solid-state chemistry. A team associated with the government of Canada’s CANMET Energy Technology Center observed the process in China and performed independent, pilot scale testing in Canada.</p> <p>Materials obtained from initial tests in CANMET pilot scale furnace did not yield material of a quality equal to cement clinker. This result was attributed to the system configuration, particularly the fluid dynamics, of the pilot scale furnace. Testing is continuing.</p> <p>Expected benefits of co-production of electricity and clinker include: reductions in SO_x and CO₂ emissions, reduced landfilling and costs associated with disposal of fly ash, and decreased cost of clinker. Coal consumption in the power plant is reduced slightly. Corrosion due to SO₂ is also reduced due to the absorption of sulfur compounds during the solid-state reaction that leads to the formation of the belite clinker.</p>

Table A.1. Process Innovations	
Basic Information	Description
<p>Innovative Electricity Supply: Wind Power</p> <p>Applicable Section: 2.3</p> <p>Company/Location: Lafarge, Port-La-Nouvelle-Signeau, France</p> <p>Applicable Issues: Resource Productivity, Climate Protection, Emission Reduction, Regional Development</p> <p>References: <i>Lafarge and the Environment, 2001.</i></p> <p>Stage of Development: Commercially available</p>	<p>Wind blows constantly at more than 7 meters per second over 5% of the Languedoc-Roussillon region, creating good conditions for wind power. In 1991, a 220 kW windmill was installed at Lafarge Ciments quarry as an experiment. Due to its success, a total of fifteen windmills have been installed at the quarry (5 in 1995 and 10 in 2000) with an installed capacity of 8.8 MW, which is enough electricity to power a town of 10,000 inhabitants. It is also the largest wind farm, in terms of electricity generating capacity, in France. Lafarge Ciments supplied the material needed to build the foundations and logistics support during the work. The site was first offered as a test site, then the technology proved viable, incremental increases in capacity have occurred. Partnering with the wind power company and the government sector assisted the project's success.</p>
<p>Innovative Use of the Cement Process for Disposal of Hazardous Wastes: Injection of CFCs</p> <p>Applicable Section:</p> <p>Company/Location: Taiheiyo, Tokyo</p> <p>Applicable Issues: Community Well Being, Shareholder Value Creation</p> <p>References: Taiheiyo Cement Corporation, <i>Environmental Report 2000.</i></p> <p>Taiheiyo Cement Corporation, <i>CFCs Decomposition System.</i></p> <p>Stage of Development: Demonstrated</p>	<p>A joint research project with Tokyo Metropolitan Government and Taiheiyo has resulted in the successful destruction of CFCs in a cement rotary kiln. The system involves the injection of CFCs into a cement plant rotary kiln (no modifications needed). At high temperatures (~1,450 degrees C), the CFCs decompose completely in seconds generating hydrochloric and hydrofluoric acids, which are then reacted with alkaline calcium and fixed to form non-toxic and harmless clinker materials. The process destroys a high percentage of the CFCs (99.99%) and does not create a need for additional treatment of the kiln's flue gas.</p> <p>This technology has created a potential market where municipalities pay cement companies to destroy CFCs.</p>

Table A.2. Product Innovations	
Basic Information	Description
<p>Use of waste material in cement: Cement from contaminated sludge and soils</p> <p>Applicable Section: 2.3</p> <p>Company/Location: Endesco Services, New York, USA; Taiheiyo, Japan</p> <p>Applicable Issues: Resource Productivity, Climate Protection, Ecological Stewardship, Community Well Being</p> <p>References: <i>Plant Engineering.</i></p> <p>Taiheiyo Cement Corporation, <i>Environmental Report 2000.</i></p> <p>Stage of Development: Commercially available</p>	<p>Several companies are working on using waste sludge and soils as feedstock for cement. Activities at Brookhaven National Laboratory in the United States and Taiheiyo in Japan are discussed in this summary.</p> <p>Research to develop a technology called Cement-Lock[®] was conducted at Brookhaven National Laboratory, in partnership with U.S. Environmental Protection Agency and the U.S. Army Corps of Engineers. ENDESCO Services Inc, a subsidiary of the Gas Technology Institute, is running the demonstration plant in New York. The Cement-Lock[®] process uses contaminated sludge and soils from hazardous waste clean-up sites to make construction grade cement. The thermochemical process destroys PCBs, insecticides, benzo-chloro-cyclic compounds (including dioxins and furans) and other toxic chemicals, and it immobilizes heavy metals. A demonstration scale plant will process 100,000 cubic yards of dredged harbor sediment from the New York/New Jersey harbor. From the perspective of a dredging operation, the process is economical with waste tipping fees avoided and revenue generated from the sale of cement. Payback for a plant is 3-4 years. Mike Mensinger of ENDESCO Services Inc, said: "We are looking to establish a sustainable industry that will benefit the local economy by generating permanent jobs and a readily marketable product." (<i>Plant Engineering</i>, 1998)</p> <p>Taiheiyo is using waste sludge as raw material for cement from various sources including sludge generated from water purification, sewage sludge and sludge cake, and sludge incinerator ash. "Super Lime" is a new type of cement raw material produced by mixing dewatered sludge with lime-derived additives followed by drying, deodorizing and sterilizing. This process occurs at the sewage treatment plant and then the Super Lime is transported to the cement plant. N-Powder system is a multi-purpose lime-derived powder that can be mixed with dewatered sludge that has been shipped to a central location, dried, palletized, and sterilized to become raw material for cement production.</p>

Table A.2. Product Innovations

Basic Information	Description
<p>Use of waste material in cement: CemStar process using blast furnace slag</p> <p>Applicable Section: 2.3</p> <p>Company/Location: TXI Industries, Texas, USA</p> <p>Applicable Issues: Resource Productivity, Climate Protection; Shareholder Value</p> <p>References: Burgert, Truemper, Mangan</p> <p>Stage of Development: Commercially available</p>	<p>CemStar is a patented process developed by Dallas-based Texas Industries Inc. (TXI) that adds waste steel slag to the cement raw material mix to yield larger batches of high-quality Type I Portland cement, while producing less pollution and using less energy. The process uses slag, a waste byproduct of steel production usually sold at low prices for reuse in road construction. Two-inch chunks of electric arc furnace slag are injected into the cement kiln at the beginning of the process, without a costly grinding step. The slag mixes and bonds with other ingredients in the kiln so that one ton of slag yields a ton of clinker (Truemper 2000). Portland cement made using CemStar is the same as that made with standard raw materials. Use of the CemStar process increases cement production by an average of 10 percent, allowing plants to expand production without large capital expenditures (Truemper 2000). The process significantly decreases carbon dioxide (CO₂) emissions, conserves natural resources, and reduces energy requirements 10-15 percent (Mangan 1997). Furthermore, the value of the slag is 20 times higher than its road construction value (Mangan 1997).</p> <p>TXI Cement and Chaparral Steel (jointly owned) had formed a project called the “Systems and Technology for Advanced Recycling” (STAR) project in order to seek ways to work together and to generate “zero waste” (Mangan 1997). Slag had been used in cement before but only after going through a costly grinding step. A team of research, operations, technical, and management staff from both organizations developed the CemStar method to add the slag in large pieces directly into the clinker. Support from management and staff enabled the developing, testing, and implementation of this technology. Also, since the companies were jointly owned (TXI owned 84 percent of Chaparral at the time), savings were increased. A commitment to “zero waste” and industrial ecology were also significant drivers to think creatively (Burgert 1997).</p> <p>By implementing CemStar in two of its plants, production capacity increase by 9 percent in FY 1995 (and outyears), therefore TXI generated several million dollars of pretax income on an investment of less than \$1 million (Mangan 1997). Additionally, TXI has licensed the process and will be earning revenue from its use at other facilities.</p>

Table A.2. Product Innovations	
Basic Information	Description
<p>Use of waste material in cement: Ecocement</p> <p>Applicable Section: 2.3</p> <p>Company/Location: Taiheiyo, Tokyo</p> <p>Applicable Issues: Resource Productivity, Climate Protection, Community Well Being, Shareholder Value Creation</p> <p>References: Taiheiyo Cement Corporation, <i>Ecocement</i></p> <p>Taiheiyo Corporation, <i>Introduction to Environmental Technologies</i></p> <p>Stage of Development: Commercially available</p>	<p>Ecocement is a cement that replaces 50% of the traditional cement raw materials with ash generated by the incineration of municipal solid waste and sewage sludge. It has been recognized as “Type A Energy Efficient Cement” by the Japanese Institute of Civil Construction, Ministry of Construction with the following characteristics:</p> <ul style="list-style-type: none"> - Rapid hardening, similar to high early strength cement. - Short initial setting time (approximately 20-40 minutes) - Handling time that can be adjusted to suit particular applications by the addition of retarding admixtures. <p>During the Ecocement process, chinaware fragments contained in the incineration ash are used and metal wastes are extracted and recycled.</p>
<p>New pozzolanic additives: Palm Oil Fuel Ash</p> <p>Applicable Section: 3.2</p> <p>Company/Location: University of Technology, Malaysia</p> <p>Applicable Issues: Resource Productivity, Ecological Stewardship, Shareholder Value Creation</p> <p>References: Hussin and Awal</p> <p>Stage of Development: Experimental</p>	<p>Palm oil fuel ash is a waste material obtained from burning palm oil husk and shell in palm oil milling industry. Around two hundred palm oil mills are now under operation in Malaysia alone, where thousands of tons of ash are produced annually and disposed of without commercial return. Ash from a Malaysian mill was collected and ground. Tests of concrete and mortar specimens prepared with palm oil fuel ash exhibited better resistance to sulfate attack.</p>
<p>More sustainable concrete: Addition of pozzolans and admixtures to improve the durability of concrete</p> <p>Applicable Sections: 3.2; 2.3</p> <p>Company/Location: Numerous universities, government laboratories, cement and concrete companies</p> <p>Applicable Issues: Resource Productivity, Climate Protection, Regional Development</p> <p>References: Swamy and Darwish; Taheri and van Breugel; Rodriguez-Camacho; Bouzoubaa et al.</p> <p>Stage of Development: Commercially available</p>	<p>Increasing the durability of concrete can reduce resource use, carbon dioxide emissions, and production of demolition waste. It can also lead to longer-lasting infrastructure, improving the ability of regions to develop in a cost-effective way. The durability of Portland cement concrete can be improved by adding mineral admixtures (i.e., fumed silica), pozzolanic materials or by-products in combination with water reducing admixtures (superplasticizers). Blast furnace slag has been proven to decrease the permeability of concrete and provides corrosion resistance and improves immobilization of other wastes. In addition to using by-products as pozzolans, incinerator ash and sintered coal ash can be used as fine aggregates and sintered sewage sludge or glass cullet can be used as coarse aggregates.</p>

Table A.2. Product Innovations

Basic Information	Description
<p>More sustainable concrete: Products for concrete repair and longevity</p> <p>Applicable Section: 3.2</p> <p>Company/Location: Various</p> <p>Applicable Issues: Resource Productivity, Climate Protection, Regional Development</p> <p>References: Pera and Ambroise, <i>Advances in concrete technology</i>; Dimmick</p> <p>Stage of Development: Demonstrated</p>	<p>Another way to increase the durability of concrete is to repair or prevent destruction of existing concrete infrastructure. On a long-term, lifecycle basis, this practice can reduce resource use, carbon dioxide emissions, and production of demolition waste. Timely repairs can often avoid large economic costs associated with travel delays or diversions.</p> <p>Composites based on magnesium phosphate cement can be used to quickly repair normal Portland cement materials. Although magnesium phosphate cements are inherently brittle, use of an appropriate reinforcement provides them with properties equivalent to those of ordinary Portland cement (Pera and Ambroise).</p> <p>Epoxy Polymer Concrete has also been applied over concrete roads and bridge decks and has proven to improve their longevity (Dimmick).</p>
<p>More sustainable concrete: Incorporation of recycled wood chips in concrete</p> <p>Applicable Section: 3.2</p> <p>Company/Location: Japan and elsewhere</p> <p>Applicable Issues: Resource Productivity, Climate Protection</p> <p>References: Kasai et al.; Sarja</p> <p>Stage of Development: Demonstrated</p>	<p>Wood chips, from used construction timber, can be incorporated with cement to produce concrete suitable for various construction applications. This practice utilizes an abundant waste material (used construction timber) and can reduce the cost of concrete. Used wood is crushed in a hammer-mill. The resulting wood chips are placed into a steel mold and a cement paste is injected. The use of wood chips is likely to produce an inexpensive lightweight, tough concrete material.</p>
<p>High-value products with environmental benefits: Porous Concrete</p> <p>Applicable Section: 3.2</p> <p>Company/Location: Taiheiyo, others; Japan</p> <p>Applicable Issues: Ecological Stewardship</p> <p>References: Tamai and Matsukawa; Sakai et al; Yanagibashi and Yonezawa; Fujiwara et al.; Taiheiyo Cement Corporation, <i>Environmental Report 2000</i></p> <p>Stage of Development: Demonstrated</p>	<p>Porous concrete with interconnected voids is being investigated as a material capable of environmentally-helpful functions such as providing a medium for growth of greenery, purifying water, absorbing sound, allowing drainage of water through pavement, and many other potential uses.</p> <p>Several ways of producing porosity have been studied (see references). Generally, the concrete is produced without fines. One innovative method for producing porous cement involves using a polymer admixture to form a mortar, coating coarse aggregates with that mortar, followed by fusing the aggregates in a vibratory mold. In some applications, a weak organic acid, water retaining material, and solid fertilizer that is soluble in citric acid are filled into the voids. Additional fertilizer and seeds are applied to the surfaces so that greenery grows in the pores.</p> <p>Taiheiyo is marketing a porous concrete, Plantation Concrete, as a technology to “promote the greening of metropolitan areas.”</p>

Table A.2. Product Innovations	
Basic Information	Description
<p>High-value products with environmental benefits: Clean up of contamination and immobilizing wastes using cement</p> <p>Applicable Section: 3.2</p> <p>Company/Location: Various</p> <p>Applicable Issues: Ecological Stewardship</p> <p>References: <i>World Cement</i> Oct 2000; Pera et al.</p> <p>Stage of Development: Demonstrated</p>	<p>Several examples of cement usage for environmental cleanup include:</p> <ul style="list-style-type: none"> • “Accelerated Carbonation Technology” may be used to “clean-up” contaminated soil. Mixing contaminated soils, carbon dioxide and specially-modified cements (e.g., Blue Circle’s EnvirOceM) results in the cement reacting with carbon dioxide and locking in the contaminants. The cement ends up being carbonated rather than hydrated which improves contaminant stabilization characteristics of the product. Blue Circle has exclusive license agreements for the process and patents in the UK, US and Canada. This application reduces leaching of metals, compared to Ordinary Portland Cement, is fairly easy to apply, and is more cost effective than “dig & dump” (<i>World Cement</i>, Oct 2000) • Metakaolin can be used as an additive to concrete to produce a very impermeable product that is suitable for immobilizing wastes, especially latex waste. (Pera et al.)

Table A.2. Product Innovations

Basic Information	Description
<p>Cement with increased reactivity: Energetically Modified Cement</p> <p>Applicable Section: 3.2</p> <p>Company/Location: EMC</p> <p>Applicable Issues: Resource Productivity, Climate Protection</p> <p>References: Lygren; ISG Resources, SINTEF, Elfgrén and Jonasson.</p> <p>Stage of Development: The technology has been operating at 1 tonne/hr in Sweden since 1994 and has been tested at 10 tonne/hr. Commercial scale plant (60 tonnes/hr or 400,000 tonnes/annum using six 10 tonne/hr units) producing EMC cement containing at least 50% fly ash is planned (construction expected to begin in 2002).</p>	<p>Blending Portland cement with various other pozzolanic or cementitious substances (such as blast furnace slag, fly ash, limestone, etc.) has been occurring for a long time. However, there are some obstacles to using high volumes of these additives in concrete. One important constraint is the early strength development requirements included in product standards (blended cements take longer to develop their strength and often do not meet standards without additives). Energetically Modified Cement (EMC) is a patented technology that has overcome this obstacle. By intensively grinding and activating the OPC together with the pozzolan, the surfaces of the particles are activated. The investigators of this technology believe that the activation creates a network of sub-micro cracks, micro defects and dislocations of the cement particles that provide a deeper penetration of the water into the cement particles, so a higher percentage of the potential binding capacity of the OPC is used (Elfgrén and Jonasson). In addition, this process also allows inert fillers, such as fine quartz sand, to be activated. The EMC technology is based solely on grinding; no additives of any kind are used.</p> <p>Evaluations and tests of concretes and mortars made with EMC have been conducted in Europe (by SINTEF) and the United States (by an independent material testing laboratory). The US tests, conducted in August 2001, made the following observations:</p> <ul style="list-style-type: none"> ▪ The EMC grinding process did not produce any super fine materials, but increased the <10 micron fraction as well as the overall specific surface area (an indicator of cement and pozzolan reactivity). ▪ The EMC made with 50/50 OPC and a fly ash showed 40% higher strength after 24 hours than the OPC, but the strength development lagged behind OPC at 3-7 days, reaching an equal strength at 28 days. ▪ EMC performed “significantly” better than Portland-pozzolan blended cements with 20-40% fly ash. ▪ EMC with fly ash allowed for a 10% reduction in water-cement ratio, translating to higher long-term strength. ▪ EMC showed slightly improved sulfate resistance. ▪ The workability of EMC was better than the reference OPC.

Table A.2. Product Innovations

Basic Information	Description
	<p>The EMC grinding process is an independent process, conducted subsequent to production of ordinary Portland cement. This could occur at a cement plant or a concrete production facility. Adding an EMC grinding facility would incur capital cost (about \$15M for a 400,000 – 500,000 tonnes/annum plant) and O&M costs typical of a grinding plant. Because the cost of fly ash, quartz sand, or other fillers are significantly less expensive than the cost of producing ordinary Portland cement, the company marketing the EMC technology contends that the cost of producing EMC cement is considerably lower than the cost of producing Portland cement.</p> <p>EMC cement using quartz sand has been successfully used on a number of test objects, the latest of which was a bridge for the Swedish State Road Building Commission.</p>
<p>Cement-like products produced in new ways: Metakaolin from Paper Sludge</p> <p>Applicable Section: 3.2</p> <p>Company/Location: National Institute of Applied Sciences, Lyon, France</p> <p>Applicable Issues: Resource Productivity, Climate Protection, Community Well Being</p> <p>References: Pera and Ambroise</p> <p>Stage of Development: Experimental</p>	<p>Research has been carried out to convert paper sludges from de-inking and water-treatment processing plants into pozzolanic material. In the paper recycling process, the fraction of wastepaper not recovered becomes de-inking sludge. Normally, this sludge would be disposed in a landfill. There is an estimated 5.8 million tonnes of this waste material produced in the European Union alone. The sludge contains clay minerals such as kaolinite, talc and muscovite, calcium carbonate, titanium dioxide and other additives. The process involves decomposing the kaolinite to metakaolin at 100°C. At higher temperatures, the metakaolin undergoes further reactions. Other components of the paper sludge are also transformed. Laboratory testes were performed in an electrical fixed-bed furnace. The calcination led to a reactive pozzolanic material (a mixture of metakaolin and calcite) usable in the concrete industry.</p>
<p>Cement-like products produced in new ways: Preparation of Portland Cement Components by PVA Polymerization</p> <p>Applicable Section: 3.2</p> <p>Company/Location: Laboratory research performed at the University of Illinois, USA, supported by US Air Force</p> <p>Applicable Issues: Resource Productivity, Climate Protection</p> <p>References: Lee et al.</p> <p>Stage of Development: Experimental</p>	<p>A method utilizing nitrate salts and colloidal silica has been developed that allows the key components of Portland Cement to be formed at significantly lower temperatures than clinker – at 700°C. The process produces fine powders that are extremely reactive and develop strength quickly during hydration. Since Tetracalciumaluminoferrite is not required, the product is compatible with reinforcing materials that corrode in contact with ordinary Portland cement. Nitrate salts and colloidal silica are co-dissolved in water with 5 volume percent (poly) vinyl alcohol. The water is evaporated to produce a polymeric material. The polymer is dried, ground, then calcined at 700°C.</p>

Table A.2. Product Innovations	
Basic Information	Description
<p>Cement-like products produced in new ways: Ceramicrete</p> <p>Applicable Section: 3.2</p> <p>Company/Location: Argonne National Laboratory, Illinois, United States</p> <p>Applicable Issues: Resource Productivity, Climate Protection</p> <p>References: Argonne National Laboratory</p> <p>Stage of Development: Demonstration</p>	<p>According to the developers, “Ceramicrete (chemically bonded ceramic) is formed by mixing magnesium oxide powder and soluble phosphate powder (common, low-cost materials) with water, resulting in a nonporous material with compressive strength higher than that of concrete.” “Ceramicrete can be made with commercially available equipment that mixes the powder components into the binder. The wet material (binder, aggregates, and water mixture) can then be pumped, gunned, or sprayed, also with commercially available equipment.”</p> <p>It can be used as a structural material, an impervious layer around contaminated material, a sealant or coating, or in many other uses. It is being promoted as treatment technology prior to long-term disposal of hazardous materials, including radioactive and mixed wastes. This technology can also convert common wastes into commercial and industrial products that serve various markets.</p>
<p>Cement-like products produced in new ways: Sulfur Concrete</p> <p>Applicable Section: 2.3</p> <p>Company/Location: Taiheiyo, Tokyo</p> <p>Applicable Issues: Resource Productivity</p> <p>References: Taiheiyo Cement Corporation, <i>Environmental Report 2000</i></p> <p>Stage of Development: Commercially available</p>	<p>Sulfur concrete is made from sulfur collected from the petroleum refining process and coal ash from coal-burning thermal power stations. The concrete is made from 100% recycled resources. The process applies vibration and pressure to a mixture of heated sulfur and coal ash. Hardened sulfur concrete is dense and acid-resistant enough to be used in the application areas where Portland concrete cannot be used.</p>
<p>Cement-like products produced in new ways: Polymer concrete made from recycled plastic bottles</p> <p>Applicable Section: 3.2</p> <p>Company/Location: Several groups throughout the world, including Lafayette University and The University of Texas in Austin.</p> <p>Applicable Issues: Resource Productivity</p> <p>References: Reibeiz and Fowler, 1996 a&b; Dimmick</p> <p>Stage of Development: Demonstration</p>	<p>Polymer concrete (PC) consists of organic polymers – typically unsaturated polyesters that bind together inorganic aggregates – essentially replacing the hydraulic binders in OPC with organic polymers. Polymer concrete can be used alone or as an overlay or coatings on ordinary Portland cement concrete to dramatically increase the durability and lifetime (see above). Recently, investigators have studied the use of resin obtained from recycled PET bottles (water and carbonated beverage containers). Recycled-PET resin based PC is stronger and cheaper than conventional PC. Recycling PET into PC also aids in waste disposition.</p>

Table A.2. Product Innovations

Basic Information	Description
<p data-bbox="203 289 743 352">Inexpensive building products that use cement: Bamboo and cement construction</p> <p data-bbox="203 380 743 415">Applicable Section: 3.2</p> <p data-bbox="203 443 743 562">Company/Location: Simon Velez, Architect; Columbia (South America); Zero Emission Research Institute; Taiheiyo Cement</p> <p data-bbox="203 590 743 688">Applicable Issues: Resource Productivity, Climate protection, Community Well Being, Regional Development</p> <p data-bbox="203 716 743 751">References: Pauli, G.</p> <p data-bbox="203 779 743 842">Stage of Development: Currently available</p>	<p data-bbox="751 289 1412 688">Architect Simon Velez has built a tradition of using local materials for housing, offices, and even factories. The building system he developed for use in Columbia involves filling the joints between bamboo with cement. This technique has been applied to both small houses and large structures, e.g., the ZERI pavilion, with a roof of 2,000 square meters. The structures built using this technique recently survived a substantial earthquake. The use of cement improves the traction strength of bamboo to the point that on the basis of its weight, is better than steel. This technique makes housing affordable; the estimated cost of a two-story house is Euro 7,000.</p> <p data-bbox="751 716 1412 888">Over a decade ago, Taiheiyo developed another system involving cement and bamboo -- cement board produced with a blend of bamboo fibers and cement. For each ton of cement used in the cement board, there is a need for four times the same amount of bamboo, so this technology also sequesters carbon.</p>

Table A.3. Management Innovations

Basic Information	Description
<p>New siting approach: Central siting sponsored by a federal government</p> <p>Applicable Section: 2.1</p> <p>Company/location: Taiwan Cement Corp and Southeast Cement Corp; Hoping Cement Industrial Zone, Taiwan, East coast</p> <p>Sustainability considerations: Resource conservation (because it fosters industrial ecology approaches and improves land use); Community Well-Being</p> <p>Reference: East Asian Executive Reports. 1997.</p>	<p>Centralized siting of a group of cement plants in the Hoping Cement Industrial Zone, sponsored by Taiwanese government, was designed to reduce environmental impact and land use. In Taiwan, environmental concerns and the near exhaustion of limestone reserves on the West coast meant that the cement industry needed a new site. In an effort to reduce environmental impact and decrease the approval and permitting process, the government has set up the Hoping Cement Industrial Zone on the East coast. The new zone covers about 100 hectares of land valued at about NT\$4.23 billion (US\$151.3 million). An industrial port and an independent power plant are also planned for the site. Taiwan authorities plan for three cement makers to move into the zone.</p>
<p>New siting approach: Siting a new facility at a volunteer site</p> <p>Applicable Section: 2.1</p> <p>Company/location: Hazardous waste facilities in Alberta and Manitoba, Canada, and Greensboro, North Carolina.</p> <p>Sustainability considerations: Stakeholder involvement</p> <p>Reference: Pushchak, R. and C. Rocha.</p>	<p>Seeking a volunteer location for a new facility, instead of seeking approval after choosing a site, has been successfully used for hazardous waste facilities in Alberta and Manitoba, Canada, and with a hazardous waste incinerator in Greensboro, North Carolina. The process resulted in improved community relations and less costly legal processes.</p> <p>The process is not always successful and requires direct work with the community, as well as careful selection process among volunteers. The cement industry would face additional challenges to this approach, because a site near limestone or other cement plant feedstocks would be needed, limiting the choice of sites. However, it should be feasible to find both availability of the resources and a willing community.</p>

Table A.3. Management Innovations

Basic Information	Description
<p>New business concept: Use of an old cement kilns as a composting and waste processing facility</p> <p>Applicable Section: 2.1</p> <p>Company/Location: Rondeco and others, Stockholm, Sweden; Taiheiyo</p> <p>Applicable Issues: Community Well-Being; Ecological Stewardship</p> <p>References: ZERI (2001); ZERI (2000).</p>	<p>The City of Stockholm, in partnership with a company called Rondeco and a non-profit organization called ZERI, converted an old cement facility into an advanced composting facility. The conversion used about 80% of the infrastructure of the cement plant, including the kiln, the dock for barges, silos for raw materials and finished product, weighing stations, and conveyer belts. The benefits include reduced decommissioning costs, increased landfill life, reduced waste charges, and saleable compost. Solid municipal waste, wastewater treatment sludge, and other raw materials arrive by boat and, after an initial sorting, are introduced into the kiln from the docks using conveyer belts, minimizing air pollution generated by trucks for transportation. Done as a batch process, the mixture spends one day in each of three compartments within the kiln-composter, using natural microbial activity to break the organic matter down into raw compost. Neither heat nor chemicals are added; heat is produced from the natural process of microorganisms digesting the mixture. During the second day, the process temperature reaches 70°C. Each batch of compost is monitored for oxygen, water content, and the carbon-nitrogen ratio. After three days in the kiln-composter, the material is unloaded onto a conveyor and run through a primary screen to sort out the non-biodegradable materials, such as metals and plastics. As much as possible of these materials is sent for recycling with the small remainder sent to the landfill. The compost is matured in storage silos for 6 weeks before it is analyzed, dried, made into pellets, and packaged for sale. Additionally, excess heat and CO₂ is used in a greenhouse for growing tomatoes and other vegetables. A pilot scale version of this plant generated 7 to 8 tonnes of compost from select raw material sources each day. This first cement kiln plant will increase production from 80 tonnes of compost per day to 300 tonnes per day, ultimately to an estimated 1,000 tonnes of waste into compost each day. An estimated 10% of all household waste generated in Sweden could be dealt with at Stora Vika.</p> <p>The Taiheiyo Cement company in Japan recently signed up to use the first phase of the Rondeco composting technology to treat waste before using it in cement production.</p>
<p>New Business Concept: Metal recovery from cement kilns</p> <p>Applicable Section: 3.3</p> <p>Company/Location: Taiheiyo, Japan</p> <p>Applicable Issues: Resource Productivity, Shareholder Value Creation</p> <p>References: Taiheiyo Cement Company, <i>Environmental Report 2000</i>.</p> <p>Stage of Development: Commercially viable</p>	<p>Recovery and recycle of precious metals is occurring at Taiheiyo using a specially designed recovery system. Incinerator and combustion ashes are used as raw materials and/or fuel for cement. Valuable metals such as copper, vanadium and nickel can be present in the ash in small quantities. A solvent extraction method is being used to concentrate the metals of interest so that they can be sold and used as non-ferrous resources.</p>

References for Appendix A

- Argonne National Laboratory, "Technology Tour Commercialization/Licensing Opportunity: Chemically Bonded Ceramic ("Ceramicrete")" available at <http://www.techtransfer.anl.gov/techtour/ceramicrete.html>
- Bouzoubaa M., Zhang M.-H., Malhotra M.V., " Laboratory produced, high volume fly-ash blended cements: compressive strength and resistance to chloride ion penetration of concrete," *Cement and Concrete Research*, **30**, 1037-1046 (2000).
- Burgert, Philip. 1997. "Environment rules challenge; breakthrough technology seen needed for steel industry." *American Metal Market*, 1997, 6.
- Dimmick, F.E., Sr., "15-Year Tracking Study: Comparing Epoxy Polymer Concrete to Portland Cement Concrete Applied on Slab-on-Grade and Bridge Decks," pp. 211-231 in Properties and Uses of Polymers in Concrete, J.J. Fontana, A.O. Kaeding, and P.D. Krauss [Eds.], American Concrete Institute, Michigan, 1996.
- Elfgren, L. and J-E Jonasson, "Energetically Modified Cement (EMC) and Ordinary Portland Cement (OPC) – A Comparison," Lulea, Sweden: Center for High Performance Cement, Lulea University of Technology (report).
- Fujiwara H., Tomita R., Okamoto T., Dozono A., and Obatake A., "Properties of High-Strength Porous Concrete," pp. 173-187 in Recent Advances in Concrete Technology, V.M. Malhotra [Ed.], American Concrete Institute, Michigan, 1998.
- Hussin, M.W. and A.S. M. Abdul Awal, "Influence of Palm Oil Fuel Ash on Sulfate Resistance of Mortar and Concrete," *Fly Ash, Silica Fume, Slag and Natural Pozzolans in Concrete*, V.M. Malhotra [Ed.], American Concrete Institute, Michigan, 1998.
- Imhof, A., "Solar Cement Plants," *ZKG International*, vol. 53, no. 8, 448-456 , 2000a.
- Imhof, A., "Calcination of Limestone in a Solar Reactor," *ZKG International*, vol. 53, no. 9, 504-509, 2000b.
- ISG Resources, Inc., Technical Evaluation of Energetically Modified Cement (EMC), confidential document prepared by ISG Resources, Inc., Material Testing and Research Facility (Cement and Concrete Reference Laboratory Approved Testing Facility), Taylorsville, GA, USA. The document is available for review upon request from Atle Lygren, EMC DEVELOPMENT AB, Chalet BALYBY, CH-1936, Verbier, Switzerland, Telephone: 011 41 277753860, email: atlee@lygren.com
- Isoo T., Takahashi T., Fukuhara K., "Using Carbonated Steelmaking Slag Blocks to Help Reduce CO₂," *American Ceramic Society Bulletin*, vol. 80, no. 1, pp. 73-75, 2001.
- Kahn, R., and P. Hill, "An Uncommon Use," *Water Environment & Technology*, 1998 (May): 44-48.
- Kasai Y., Kawamura M., Zhou J.-D., "Study on Wood Chip Concrete with Used Timber," pp. in Ed. V.M. Malhotra, Recent Advances in Concrete Technology, Farmington Hills, Michigan, American Concrete Institute, (1998): 905-928.

Lafarge and the Environment. Paris: Lafarge, 2001: 36.

Lee, S.J., E. A. Benson, W.M. Kriven, "Preparation of Portland Cement Components by Poly(vinyl alcohol) Solution Polymerization," *Journal of The American Ceramic Society*, 82.8, (1999): 2049-2055.

Lygren, A., personal communication, EMC DEVELOPMENT AB, Chalet BALYBY, CH-1936, Verbier, Switzerland, Telephone: 011 41 277753860, email: atlee@lygren.com

Mangan, A. T., "By-product synergy: a strategy for sustainable development." *Texas Business Review*, 4, 1997.

Pera, J. and J. Ambroise, "Pozzolanic Properties of Metakaolin Obtained from Paper Sludge," Ed. V.M. Malhotra. Fly Ash, Silica Fume, Slag and Natural Pozzolans in Concrete, Farmington Hills, Michigan: American Concrete Institute, 1998.

Pera J., and Ambroise J., "New Applications of Magnesium Phosphate Cements," Ed. V.M. Malhotra, Recent Advances in Concrete Technology, Farmington Hills, Michigan: American Concrete Institute, 1998:39-51.

Pera J., and Bonnin E., and Chabannet M., "Immobilization of Wastes by Metakaolin-Blended Cements." Ed. V.M. Malhotra, Fly Ash, Silica Fume, Slag & Natural Pozzolans in Concrete, Farmington Hills, Michigan: American Concrete Institute, 1998:997-1006.

Plant Engineering, "Environment and Economy Benefit from Cement-Lock[®] Technology," Plant Engineering, 52.6 (1998 Summer):A11.

Pauli, G. "Colombia Earthquake," <http://www.bamboo.org.au/iba/pavilion.htm>

Put, B. and C. Doerksen, "Gold in Fly Ash," Energy, (Spring 2000):25-28.

Rebeiz, K.S., and Fowler, D.W., "Shear and Flexure Behavior of Reinforced Polymer Concrete made with Recycled Plastic Wastes," Ed. J.J. Fontana, A.O. Kaeding, and P.D. Krauss, Properties and Uses of Polymers in Concrete, Farmington Hills, Michigan: American Concrete Institute, 1996:61-78.

Rebeiz, K.S., and Fowler, D.W., "Strength Properties of Polymer Concrete Made with Resins Based on Recycled Plastic Waste," Ed. J.J. Fontana, A.O. Kaeding, and P.D. Krauss, Properties and Uses of Polymers in Concrete, Farmington Hills, Michigan, American Concrete Institute, 1996:79-91.

Rodriguez-Camacho, R.E., "Using Natural Pozzolans to Improve the Sulfate Resistance of Cement Mortars," Ed. V.M. Malhotra, Fly Ash, Silica Fume, Slag & Natural Pozzolans in Concrete, Farmington Hills, Michigan: American Concrete Institute, 1998:1021-1027.

Sakai K., Shindoh K., and Atohida M., "Porous Concrete for Underwater Organisms in a River." Ed. V.M. Malhotra, Recent Advances in Concrete Technology, Farmington Hills, Michigan, American Concrete Institute, 1998:887-903.

Sarja A., "Structural Wood-Fiber Concrete," Concrete International 7, (1989):45-49.

Swarmy, R.N., and Darwish, A.A., "Engineering Properties of Concretes with Combinations of Cemeticitious Materials," Ed. V.M. Malhotra, Fly Ash, Silica Fume, Slag & Natural Pozzolans in Concrete, Farmington Hills, Michigan, American Concrete Institute, 1998:661-684.

Taheri, A., and van Breugel, K., "Performance of Blast Furnace Slag Cement Concrete in Simulated Aggressive Marine Environment," Ed. V.M. Malhotra, Fly Ash, Silica Fume, Slag & Natural Pozzolans in Concrete, Farmington Hills, Michigan: American Concrete Institute, 1998:717-727.

Tamai M., and Matsukawa, T., "Properties and Applications of Environmentally Friendly Porous Concrete," Ed. V.M. Malhotra, Recent Advances in Concrete Technology, Farmington Hills, Michigan: American Concrete Institute, 1998:123-140.

Taiheiyo Cement Corporation, *Environmental Report 2000*. Tokyo.

Taiheiyo Cement Corporation, *CFCs Decomposition System* (corporate brochure). Tokyo.

Taiheiyo Cement Corporation, *Ecocement* (corporate brochure). Tokyo.

Taiheiyo Corporation, *Introduction to Environmental Technologies* (corporate brochure). Tokyo.

Takano H., Matsunaga T., "CO₂ Fixation by Artificial Weathering of Waste Concrete and Coccolithophorid Algae Cultures." Energy Conversion and Management 36 (1995):697-700.

Truemper, Ingrid. 2000. "Resource recovery: Adding slag during the kiln stage of the cement making process eliminates almost a ton of CO₂ emissions." Environmental Protection, (2000):77-79.

World Cement, "Castle Tests Alternative Fuels," (Sept. 2000):8.

World Cement, "Lampang launches new high capacity production line," 28.12 (1997).

World Cement, "World First Innovation" (October 2000):21.

Yamazaki T., Takano H., Manabe E., Izumi Y., "CO₂ removal by photosynthesis and calcification using microalga" Transactions of the Materials Research Society of Japan 18A (1994):357-360.

Yanagibashi K., and Yonezawa, "Properties and Performance of Green Concrete," Ed. V.M. Malhotra, Recent Advances in Concrete Technology, Farmington Hills, Michigan: American Concrete Institute, 1998:141-149.

ZERI. 2000. "Taiheiyo signs up to use Rondeco technology." Zero Emissions Research and Initiatives. Available at <http://www.zeri.org/news/2000/expo/expo00-taiheyio.htm>.

ZERI. 2001. "Cement Goes Organic." Zero Emissions Research and Initiatives. Available at http://www.zeri.org/expo/prj_rondeco.htm.

Appendix B: Innovation Examples – Detailed Case Studies

This appendix provides two detailed case studies that illustrate real-world examples of companies that have introduced new approaches and technologies that resulted in sustainability-oriented improvements in cement companies.

The first case study tells the story of the Lampang project undertaken by Siam Cement Industry. This case illustrates how a cement company can incorporate social and environmental principles when planning, building and operating a new plant.

The second case study explains how a company called FCB developed a new energy-efficient cement plant component – a novel grinding mill called the Horomill – and worked with cement companies to test and introduce this technology into the market. This case illustrates the challenges faced by companies who supply cement plant technology and how suppliers can successfully team with cement companies to improve the energy efficiency of the cement production process.

Appendix B.1 Crosscutting Case Lampang Plant: A New Cement Plant of Siam Cement Industry

Company: Siam Cement Industry Company Limited (SCI)

Cement Plant Installation: Lampang, Thailand

For more information: Cholathorn Dumrongsak
Manager, Corporate Total Quality Promotion Center
Siam Cement Public Company Limited
1 Siam Cement Road
Bangsue, Bangkok 10800 Thailand
Tel: (662) 586-2636 Fax: (662) 586-2979
cholathd@cementthai.co.th

Overview

Siam Cement Industry Co., Ltd. ("SCI"), a wholly owned subsidiary of Siam Cement Public Company Limited ("SCC"), Thailand's largest industrial conglomerate, is the largest cement producer in Thailand, with a total annual production capacity of approximately 23 million tons. SCI has production facilities located in the North, South, and Central regions of Thailand. In 1996, SCI established a new plant known as Siam Cement (Lampang) Co., Ltd. (SLP) in the North region of Thailand, Lampang province, with an annual production capacity of 2.1 million tons.

In addition to increasing cement production capacity, SLP intended to help promote career development and quality of life in the local community in which it operates. In order to do so, SLP primarily concentrated on fostering social responsibility through community development and environmental preservation.

Context

In general, cement plants in Thailand have been located near raw material deposits as well as the major sources of demand, so most are located in the Central region, in Saraburi province. The high transportation cost of cement makes it very expensive for those cement plants to deliver cement to the northern part of Thailand. Therefore, the Lampang plant provides the company with competitive cost advantages in that region. In addition, the Lampang region also possesses a large agricultural area and abundant natural resources, including the largest lignite deposit in Thailand. The amount of fuel reserves is important to cement producers, especially in determining the life of an existing plant or in calculating the feasibility of an expansion or greenfield project.

Prior to plant construction at Lampang, the state-owned power plant, which used lignite as the primary fuel, had operating difficulties, because it was causing air pollution (mainly sulfur dioxide emissions). The local community, environmental experts, and NGOs asked the power plant to install equipment for SO₂ reduction. This indicated to SLP that industrialization without pollution control could cause serious environmental problems and draw opposition from the community.

During the planning of a new cement plant, the community did express negative views about industry and businesses, particularly large companies, affecting communities and the

environment. They also expressed concerns about the potential environmental effects of the cement plant, e.g. air pollution, dust, noise, etc.

Even though SCI is well known as a company concerned about environmental and social responsibility, the plant construction plan in Lampang was likely to be protested by local communities and NGOs. The company believes that the public is becoming more concerned about health and preservation of nature, and that all businesses affecting communities and the environment have to pay attention to such concerns. Therefore, the company developed a policy regarding environmental protection that takes into consideration environmental preservation in the planning phase of projects. The company's principles incorporated into its environmental management system go beyond the existing regulations enforced by government.

Actions

In order to continuously operate the planned project and address environmental and social issues in a sustainable way, the company took several measures related to (1) stakeholder management and (2) social, economic, and environmental project management, as discussed below.

3. Stakeholder Management

To achieve a good relationship with stakeholders, the company developed an approach that included the following steps:

1. Define a group of stakeholders and develop strategies that fit each defined group. Stakeholders include politicians, local leaders, monks, the private sector, governmental and non-governmental organizations, and the general public.
2. Explore the needs of the target groups using the following approaches:
 - Assign employees to collect information and identify the existing problems including local environmental effects about which communities are concerned
 - Arrange an open discussion and interaction between top management and all group leaders in order to create a relationship and exchange ideas
 - Develop systems to obtain and evaluate suggestions and environmental proposals from all concerned parties, and
 - Explore and analyze relevant proposals and opinions by comparing information derived from the above-mentioned approaches.
3. Develop plans to satisfy the target groups' expectations. Measures to address the identified needs were developed. Examples include:
 - During the construction period, 70% of total laborers will be hired from local community
 - For employment, the company has adjusted some parts of its hiring criteria to be compatible with the community's expectations by placing first priority on employing local people
 - With the establishment and registration of the company at Lampang, all tax and any other fee payments will directly benefit the local community, and
 - The company established a community relations budget to serve as a financial support to provide scholarships, encourage a reforestation program, support health activities for the local hospital and participate in government and social activities.

4. Continuously provide accurate information on the project and its environmental impacts that aligns with the interests of the communities.

To provide more extensive environmental information, particularly about the cement business, the company arranged cement plant visits in Saraburi Province. The objective of this program is to enable all parties to clearly understand the cement production process, advanced cement production technology and measures that demonstrate systematic management of environmental quality. Furthermore, the company also arranged plant visits for SCC's other businesses to demonstrate that the company has environmental and social responsibility policies and is committed to developing the business towards social and economic sustainability.

5. Plan to use public relations, press releases and press conferences as tools and channels to provide stakeholders with information about the progress of the project and to obtain feedback.
6. Conduct activities to develop communities in terms of education, culture, career, environmental protection, and other support
7. Establish an environmental committee comprising competent personnel from various fields to be responsible for the implementation of the community relations and environmental plan.

Some examples of efforts to help the community are found at the end of this appendix.

4. Social, Economic, and Environmental Project Management

To protect the community and environment, the company included the following activities in the various phases of the project:

8. Encourage local community to participate in plant site selection and acknowledge the project's investment cost, as well as impacts on the environment, economy and society. For selection of cement plant location, the company considered the following three types of impacts:
 - Impacts on the **environment** such as on forests, water supplies and surrounding environment.
 - Impacts on the **community** such as the need for relocation of people and changes in overall community well-being.
 - Impacts on the **economy** including investment cost, operating cost, and land improvement.
9. Design the production process to minimize the impacts on the surrounding environment throughout the local area and to reduce the need for the use of natural resources as the principal raw materials in the production process. In particular, the company:
 - developed an environmentally-improved quarrying method
 - planned to use alternative fuels and raw materials
 - incorporated state of the art technology and controlsThese are discussed below.

Environmentally-improved Quarrying (Semi-Open Cut Mining). Since the beginning of the Lampang project, the SLP Quarry Department concentrated on environmental responsibilities to minimize pollution, e.g. dust and noise, from all quarry activities and to maintain normal landscape view to public. To accomplish this goal, SLP developed an innovative method of quarrying called "Semi-Open Cut Mining" with the objective to

preserve the appearance of the mountain, restrict explosions and transportation to the quarry area, minimize dust and noise, and continuously reclaim exposed areas using reforestation. (Note: this quarrying method is also described in Appendix A, Table A1.)

The method can be compared to consuming a melon by slicing the top end first, boring inside, and then scooping the pulp out of the melon, leaving only the outer skin intact. This quarrying technique is a combines two traditional methods known as open pit mining and open cut mining. The development procedure begins by cutting away small hills to create a flat level area between the mountains. The mining operation occurs in the exposed area and the level of the mining is adjusted downward as the limestone is removed. This creates an effect that looks like the rows of seats in a sport stadium inside the quarry (see photos of a model of this process, next page).



On the outside, the outer inclined shell of the mountain remains intact. The inner crust is excavated but the shell is left wide enough to retain a stable shape that will not later cave in. This method makes it easier to fill soil on the top of the excavated areas and accelerate reforestation, instead of reclaiming the quarry at the end of its life. The equipment used in process is no different from that used in a traditional quarry.

Because the Lampang plant was to be situated in a region almost entirely devoted to agriculture, the company designed it in a way that would fit with the landscape and be environmentally improved in its operations (see photos, next page).



Use of alternative fuels and raw materials. The cement production process was designed and equipped to use industrial waste, such as artificial gypsum (a by-product of the desulfurization process in power plant), fly ash, and petroleum (pet) coke (a by-product of the steel production process), as secondary fuel and raw materials.

Use state-of-the-art technology and process controls. To minimize impact on the environment, state of the art technology and process controls were added at every stage, from raw material to the end product. Moreover, the advanced technology helps reduce the need for natural resources and power consumption, thus prolonging the life of raw materials and fuel reserves. SLP installed a rotary kiln imported from Germany with a production capacity of 5,500 tons/day and heat consumption at 717 kcal/kg clinker and three cement mills with a production capacity of 150 tonnes/hr. and power consumption at 45 kWh/tonne.

To prevent pollution and preserve the environment, SLP spent a total of US\$7.7 million in environmental investments for equipment, instrument installation and buildings. To minimize air pollution, SLP utilized three types of dust collectors: cyclones, electrostatic precipitators, and

bag filters. The electrostatic precipitators can reduce emission to less than 50 mg/Nm³, which is lower than the 200 mg/Nm³ level required by environmental regulation. This system will lead to improvements in fuel consumption and emission levels.

In addition to the above-mentioned measures, SLP adopted various management approaches related to environment, safety, and quality issues and incorporated them into the corporate business improvement model, based on the “Total Quality Management” (TQM) philosophy. This system helps the company deploy its social and environmental concerns to all relevant functions and assess their operations to ensure that all activities are carried out in compliance with its principles. SLP believes that good results are mainly driven by a good process, so performance review is primarily emphasized at the process level rather than at outcome. The systematic working process generally consists of setting up a goal, developing strategies to achieve the goal, determining the operating plan to ensure that all activities are conducted towards those strategies, and formulating a set of indicators for monitoring performance.

Since 1998, SLP has been certified under the ISO 9002 standard, which provides guidelines on matters such as management responsibility, resource management, product realization, measurement analysis and improvement, and customer satisfaction. Since 1999, SLP has been certified under the ISO 14001 standard for its environmental management system.

Outcome

SCC's business operations are based on the following four guiding principles:

- Adherence to Fairness
- Dedication to Excellence
- Belief in the Value of the Individual
- Concern for Social Responsibility

SLP has recognized the importance of social and environmental responsibilities and operates on the basis of a firm sense of responsibility towards all stakeholders. The result is a large number of small improvements, driven by a structured environmental management approach throughout SLP. As a result, SLP has been acknowledged as a model company in local area.

SLP's internal review indicates the business and environment value mainly driven by its environmental management system. The main benefits consist of:

- An increase in reliability of relations with stakeholders
- Improvement in environmental performance (a reduction of the need for natural resources and pollution protection).
- Enhancement of environmental awareness and responsibility among all parties and employees.



As a result of implementation of environmental measures, the company was able to complete the Lampang plant construction as anticipated without any obstacles. Moreover, the company has been recognized as a good corporate citizen of the community and is proud of its contributions to society and its efforts to preserve the environment. Commitment for developing its business towards social and economic sustainability enables SLP's business operations to gain acceptability and support from the public.

Lessons Learned

Siam Cement Industry feels that all companies aspiring to continuously strengthen business operations and contribute growth and prosperity have to recognize three important factors, namely concerns for economy, society, and environment. To obtain the acceptance of society, they have to commit themselves to develop their business towards social, economic and environmental sustainability. Environmental management has been identified as the key to improving environmental performance; so all businesses should develop measures to ensure environmental advantage and uniform practices throughout the company.

As a part of society, all businesses should have attitude characterized by the respect to cultures, customs, and community in local area where they operate. Although environmental regulation is not always strictly enforced in the local areas, the company should build on the basic principle of using sustainable resources and incorporate environment pollution control, good community relations, and the views of government organizations, NGOs and local businesses.

Appendix B.2 Focused Case Study: The Horomill Grinding Technology



Company:

FCB.Ciment

FOR MORE INFORMATION:

M. Etienne Simon
FCB.Ciment
50, rue de Ticleni
B.P. 376, 59666 Villeneuve d'Ascq, France
esimon@fcb-group.com

Acknowledgements

FCB.Ciment is very thankful to the pioneers who cooperated in the development of the new concept: BUZZI first, CIMENTAS, LAFARGE, and to the other cement manufacturers who have given us their confidence.

Overview

This case describes the development and marketing of the Horomill grinding technology. This new machine was developed and put into industrial operation through co-operation between a process equipment supplier FCB.Ciment and a cement company, BUZZI UNICEM. This initial team was later enlarged to LAFARGE CEMENT in the industrial production phase.

The Horomill grinding technology is based on a roller in the inner part of the shell turning at high speed, with downward pressure to the roller. Companies using the Horomill have documented reduced electricity usage up to 20% in raw mill grinding (as compared to vertical mill plants), and 40% in cement grinding.

This appendix describes:

- The context in which the HOROMILL project was initiated
- The actions taken – development process, the difficulties encountered and solutions found
- The outcome achieved

- A summary of the lessons learned.

The testimony of key partners on the cement company side: BUZZI UNICEM and LAFARGE CEMENT, shows the lessons learned from their own experience and demonstrates their interest in increasing sustainability in the cement industry through technical innovation.

Context

As in many other process industries, the production of cement requires the reduction in size of mineral blocks or parts into fine powder.

The cement manufacturing process requires two different grinding steps:

- An upstream stage after the initial crushing where raw materials (limestone and clay) are ground into a raw meal which is burnt into clinker,
- A downstream stage where clinker is ground with gypsum to make cement.

In this process the most commonly used grinding machine has been the ball mill in which materials are broken by the shock of metal balls falling onto the raw material. The efficiency of the ball mill system is very low (in the range of 5 %) as most of the energy input is lost as heat.

Alternative solutions that demonstrated less energy loss for compression were tested and developed. These include:

- The vertical mill: In a vertical mill, grinding rollers roll on a circular table (similar to antique windmills), while hydraulic jacks apply a high pressure resulting in the material being squeezed between the rollers and the table. There are energy savings when compared to a ball mill system, but those savings are impacted by the need for high ventilation of the system. Depending on material characteristics, the stability of the material bed may turn out to be very sensitive and difficult to monitor. Consequently, in the cement industry, most applications of this machine are for grinding raw materials. Current experience on clinker grinding is still limited.
- The roller press: The roller press, based on a concept patented by Dr Schönert in the late 70's, confirmed that compression grinding can result in energy savings. Nevertheless most attempts to use this machine alone (integral grinding) were disappointing from the process perspective. The roller press is now used almost only in a hybrid system combined with a ball mill. Furthermore, the extreme pressures applied between the two cylinders led to very serious mechanical and wear problems, which often impacted the reliability of operations.

In the early 1990s, the conditions in the cement industry were as follows:

- For economic as well as for environmental reasons, the major cement manufacturers were interested in reducing the energy consumption of their plants.
- Compression grinding had been identified as the potential technique, based on early experiences with vertical mills and the roller press.
- Development of the roller press was jeopardized by cement quality and process stability problems, as well as unsolved wearing and mechanical problems.

For compression grinding to be the solution, three conditions had to be satisfied:

1. In order to achieve the correct particle size for cement quality requirement, a solution was needed to permit multi-compression grinding of the material during a single transit through the machine.

2. To limit mechanical stresses, the concentration of a very high pressure resulting from the very reduced surface of contact between two cylinders of a roller press had to be avoided
3. To avoid bottlenecking in front of the roller, the material had to be stabilized and accelerated before being crushed

The Horomill grinding technology is based on a roller in the inner part of the shell turning at high speed, with downward pressure to the roller. It answered the above conditions in the following manner:

1. By scraping down several times the material to be ground under the roller, multi-compression of the particles occurs during a single cycle through the machine

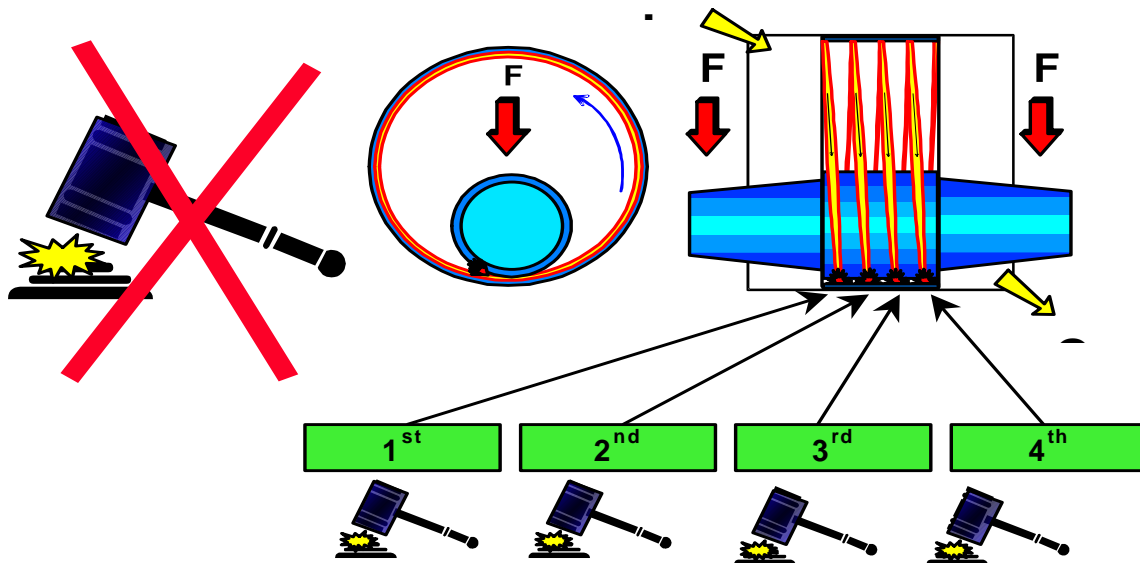

2. By having a roller pressing on the concave surface of the shell, rather than on the convex surface of another roller, the compression surface is 3 to 4 times greater. The local pressure suffered by the wear surface is thus reduced in the same proportion

(HOW INNOVATION CAN HELP THE CEMENT INDUSTRY
MOVE TOWARD MORE SUSTAINABLE PRACTICES)

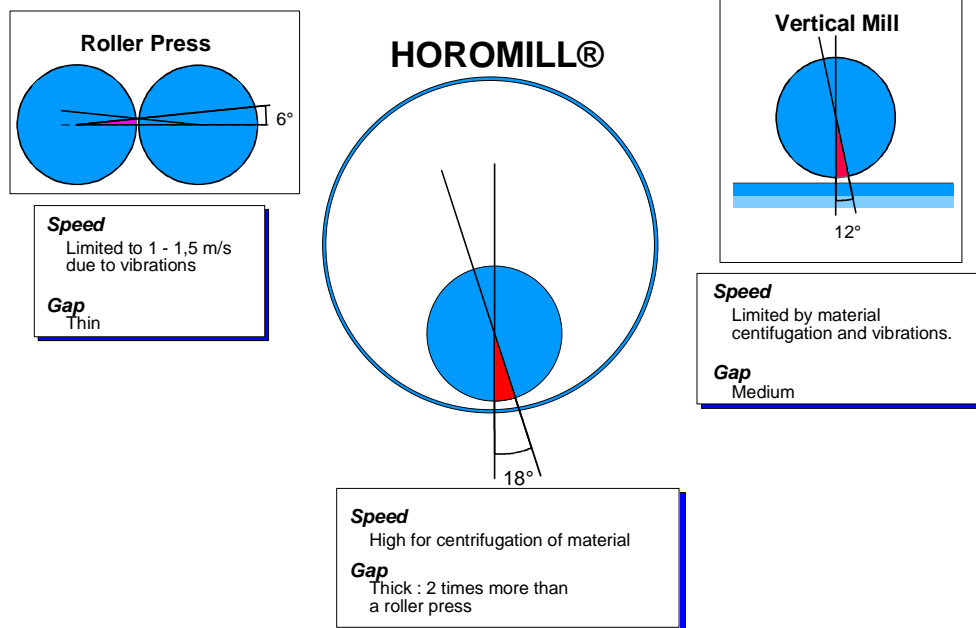

- By feeding the material inside a shell rotating above the critical speed, the material reaches an artificial high gravity and initial speed before being compressed.

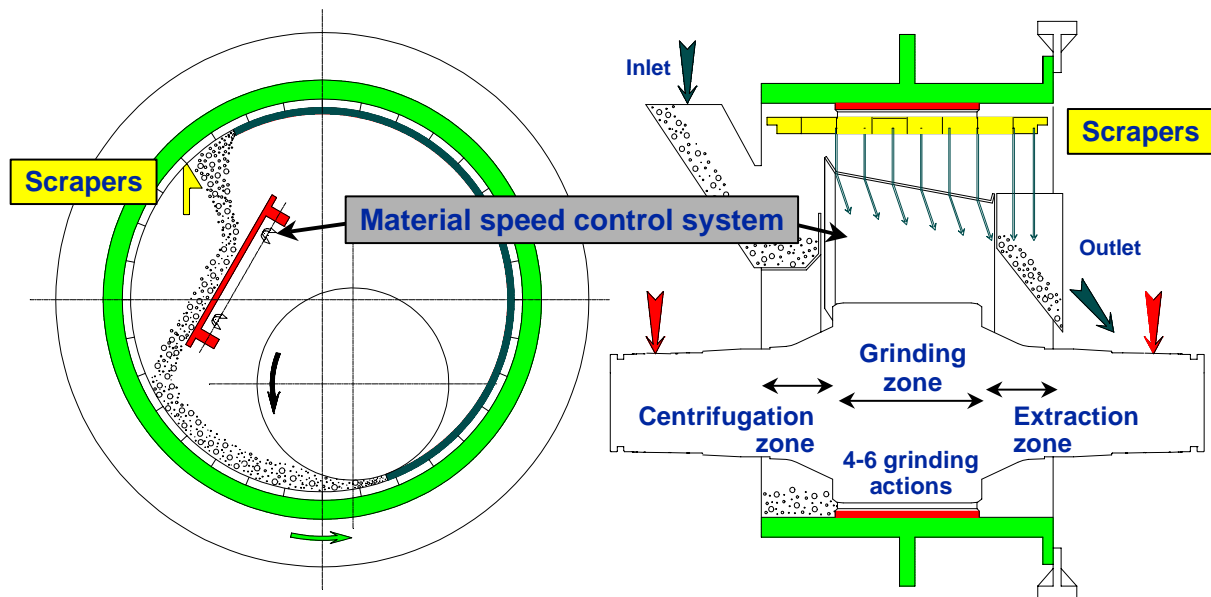

Actions

The Development Process: The Pilot Phase

From the experience of the roller press, FCB felt energy savings advantages could be achieved by applying several controlled compressions with an intermediate rearrangement of the material, rather than applying all of the compression energy at one time. This approach would

also permit the reduction of the stresses imposed on the mechanical and wear resistant parts of the machine. Different configurations were investigated on the basis of a horizontal rotating shell with one or several rollers and different ways of moving the material. The choice for the pilot machine was as follows: one single roller placed in a horizontal shell, carried into rotation and using centrifugal force in a hypercritical field to keep the flow of material under control. Taking advantage of the FCB Research Centre facilities, only a few months were needed to fine tune the machine in order to control the flow of material and to achieve what had been foreseen on paper. In September 1992, the pilot machine produced 1 t/h of cement, meeting the quality and output objectives.

The Industrial Prototype

From the beginning of the project, it was clear that the development of the machine would only be possible through the close co-operation between the user and the manufacturer. A significant investment (more than 3.5 million US \$) was needed to develop a small size industrial machine and surrounding installation. Taking into account the energy savings that such a machine would potentially provide to the cement industry, BUZZI and FCB succeeded in getting a financial grant from the European Community within the THERMIE program. This permitted the TRINO Plant in Italy to proceed with the industrial prototype phase. The prototype was ready in August 1993, and one month later it produced 25 t/h, with the same results and performances as the pilot machine.

The Industrialization Phase

The industrialization phase included identifying and developing the components and /or technologies that would be necessary for larger machines. This phase was carried out with the cooperation of potential sub-suppliers. Considering the high cost of electricity in Turkey and their booming cement production, in 1994, CIMENTAS took the decision to purchase the first large Horomill (type 3400 i.e. 3.4 m shell diameter).

The Industrial Operation Phase

Two major international cement producers, BUZZI and LAFARGE, were interested in the process and energy features of the machine. In 1995, they both demonstrated their full confidence in the machine and in FCB's capability to solve the difficulties, which were to be expected during the initial operation period.

BUZZI and its partners built a complete new cement line in Tepetzingo, Mexico, the production of which was doubly dependent on the reliability of the first new machines, which would have a production capacity four times higher than the Trino industrial prototype:

- Raw meal feeding the kiln was to be ground by a first Horomill 3800,
- Clinker was then ground into cement by a second identical Horomill.

LAFARGE selected three different machines for the following plants:

- One Horomill 3600 for DARICA in Turkey,
- One Horomill 3800 for KARSDORF in Germany,
- One Horomill 2800 for CISKOVICE in Czech Republic.

The Mechanical Optimization Phase

During the detailed engineering of the machine and in order to reduce the risks, all efforts were made to:

- Use FCB's own proven technology for design and manufacturing of key components: the shell was similar to the one of ball mills manufactured by welding in FCB's own factory. This shell was supported by hydrodynamic shoe-bearings developed for other mills. The roller

has similarities to rollers used in sugar cane mills manufactured by FCB's Sugar Department,

- Incorporate existing components from leading experienced manufacturers: big roller-bearings, hydraulic jacks, girth gear and gear box,

The result was the following machine configuration:

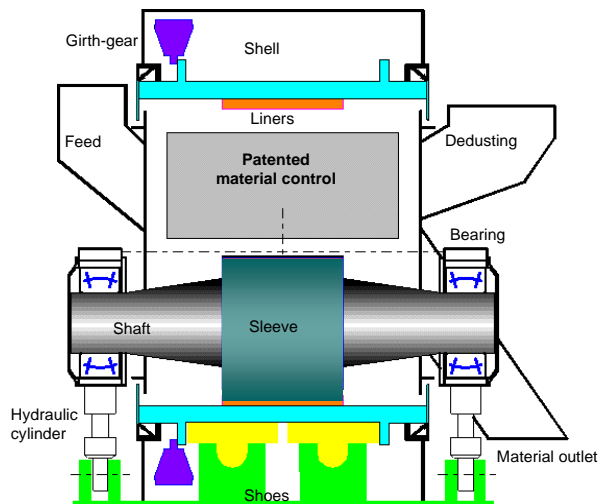
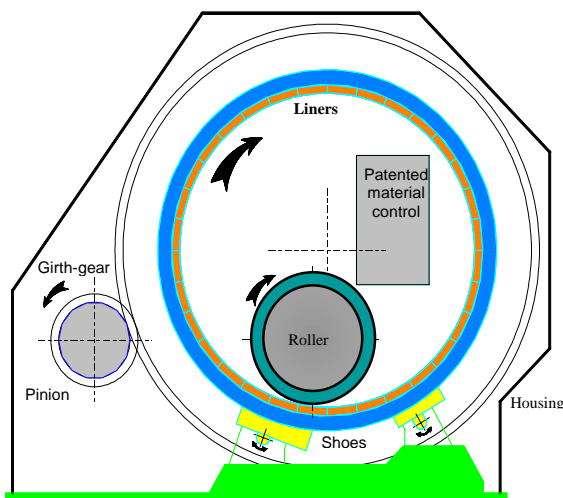
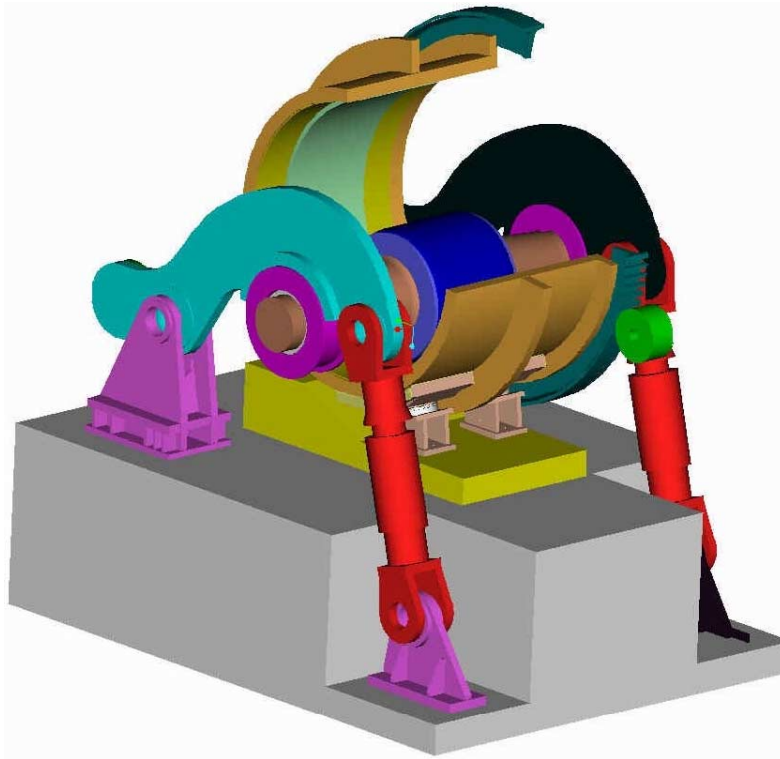

The results of the prototype, the industrial prototype and even in the initial phase of operation of the first big size machines were positive. Unfortunately, the industrial operation of several machines demonstrated that the precautions taken in design and components selection were insufficient to avoid mechanical problems and guarantee the reliability of the machine. In order to eradicate these difficulties, a special taskforce was created to identify and investigate improvements. Each time a problem appeared, the taskforce was able to analyze the origin of the difficulty, reconsider the original design, and consider several alternatives and, whenever

possible, test them on a reference machine. Once the solution was proven to be satisfactory it was implemented preventatively on all existing machines.

Such optimization was applied to:

- The complete hydraulic system
- Mechanical components such as the big roller bearings, swivels, jacks
- The shell design and manufacturing technology (originally made by welding in FCB's workshop they are now forged in a single piece)
- Wear parts and surfaces: shell liners, roller sleeve, scrapers
- The drive cinematic line.

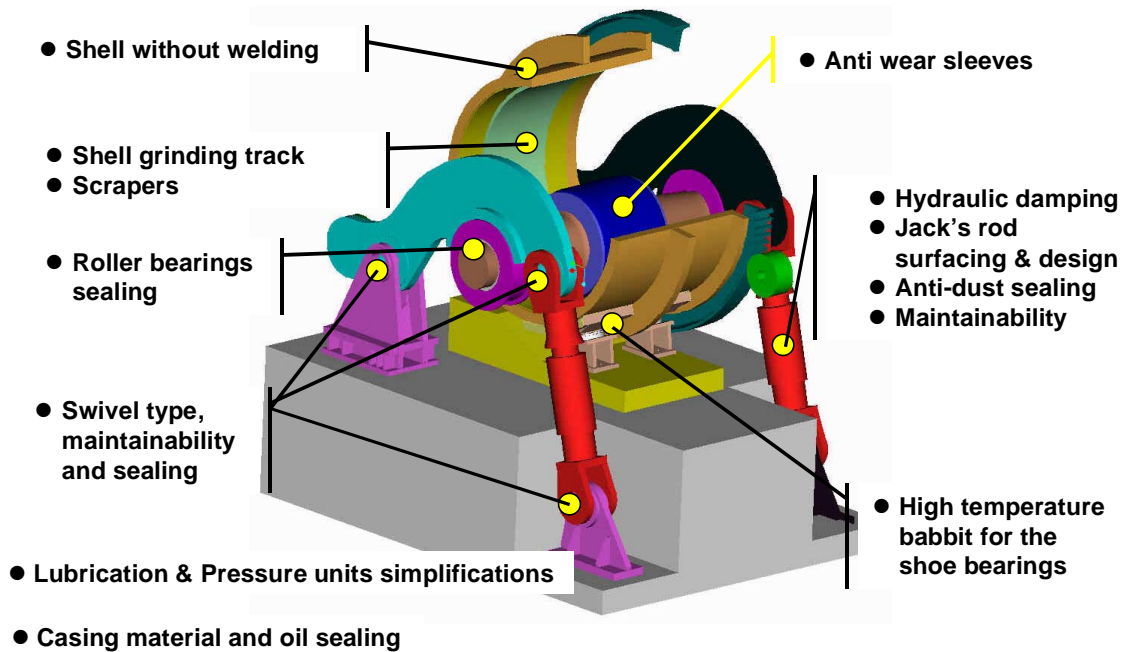

Horomill design improvements

Thus each time a mechanical improvement turned out to be necessary on one machine, all other machines were upgraded accordingly. Today trouble free operation is fully secured on all existing machines and all the improvements have been incorporated in the design of our new machines.

Marketing of the Technology

The marketing of the Horomill can be divided into three distinct phases: the initial success, the 'teething' problems (problems encountered during early operation) , and return to full commercialization.

Initial successes: Once the initial development phase had been completed a marketing campaign was launched world wide with the following message:

Get more benefit regarding energy savings from compression grinding technology without encountering the mechanical and wear problems of existing machines.

The commercial successes exceeded FCB's most optimistic expectations: a total of 12 machines of 5 different sizes were sold in less than one year. These sales occurred in 6 different countries spread over 3 continents.

Teething problems: This success had two consequences on marketing actions in the period that followed - one negative and one positive.

- Though FCB reacted vigorously and simultaneously on all fronts to provide solutions to the many teething problems that were faced, the difficulties outlined above did tarnish the commercial image of the Horomill. The decision was thus taken to temporarily put on hold the marketing to new clients until all mechanical problems of this generation of machines were solved.
- Through the task force investment that was made, FCB was able to demonstrate to existing clients its commitment to delivering a fully functioning high performance product. Indeed the industrial operation of all these first generation machines allowed FCB to acquire in a very short period of time a cumulated record of more than 200,000 operating hours in different working operations, types of products and sizes of machines.

Today's marketing strategy: FCB's current stage of marketing centers on promoting the following features:

- **Energy savings:** real energy savings to be obtained from Horomill installations (when compared to ball mills) are as follows: in raw mill grinding, up to 20% electricity has been demonstrated relative to vertical mill plants, and in cement grinding, this can rise up to 40% savings depending on the product being ground.
- **Lower capital cost:** a new Horomill installation is one of the most competitive on the market for initial investment costs compared to other leading technologies
- **Flexibility:** by its very founding principles, the Horomill has flexibility in operational use⁺⁺⁺
- **Reliability:** the reliability of this machine approaches the world best benchmarks and the associated costs of operation (wear parts and mechanical spares) are identified and continually optimized.



Future development of the Horomill in the grinding market involves testing a new range of higher capacity models, which will reply to the new demands in the evolving cement

⁺⁺⁺ In most process equipment, such as the ball mill system, the system configuration is predetermined according to the expected output. For example the ball charge distribution is set to grind a product to a given fineness. Flexibility around this set point is very limited. Process parameters are generally interdependent and adjustment of one parameter may induce changes on others thus reducing the flexibility range. With the Horomill concept the system configuration is not predetermined and no "hardware" modification is necessary to have a different product (such as a change of the ball charge). Process parameters are independent from each other and can thus be adjusted individually. The results achieved particularly by the KARS DORF Plant in Germany demonstrate that with the Horomill producers can switch between different products, with different finenesses, with or without drying, whilst always maintaining the optimum performance

installation market. The general plant concept demonstrated at the Tepetzingo plant is based on the optimum combination of the best available technologies and the maximum standardization of the equipment used. The use of four identical Horomill 3800 with two identical burning lines is a prime example of this approach. Instead of the more than 100kWh per tonne of cement produced which is commonly found, the new concept at Terpetzingo means that electricity consumption is just 80 kWh/t.

As bigger production capacity Horomills become available, the following benefits may be realized:

- Lower energy consumption with the resulting protection of the environment,
- Low initial investment costs from standardization and compactness of the installations, and
- Closely controlled operation and maintenance costs with economies in parts purchasing and reduced stocking requirements

Since the Horomill was introduced the competition from others has developed as follows:

- At least two other equipment suppliers tried to develop machines based on compression grinding – between a rotating shell and a roller for the first, or between two rotating rings for the other.
- Roller presses have generally been downgraded to run at lower pressures than initially intended, thus reducing grinding capacity and energy savings. Furthermore, hybrid systems with another grinding machines have been preferred to roller presses working completely alone.
- Progress has been made on optimizing existing vertical mills with an extension of application to cement grinding.

Outcomes

The following charts provide an overview of the results achieved with the Horomill technology.

Energy savings: Savings range from 20 to 70% (see chart below). The field of material grinding (e.g., for slag or other minerals) should be further explored, but is already showing promise, especially when extreme fineness of the final product is required.

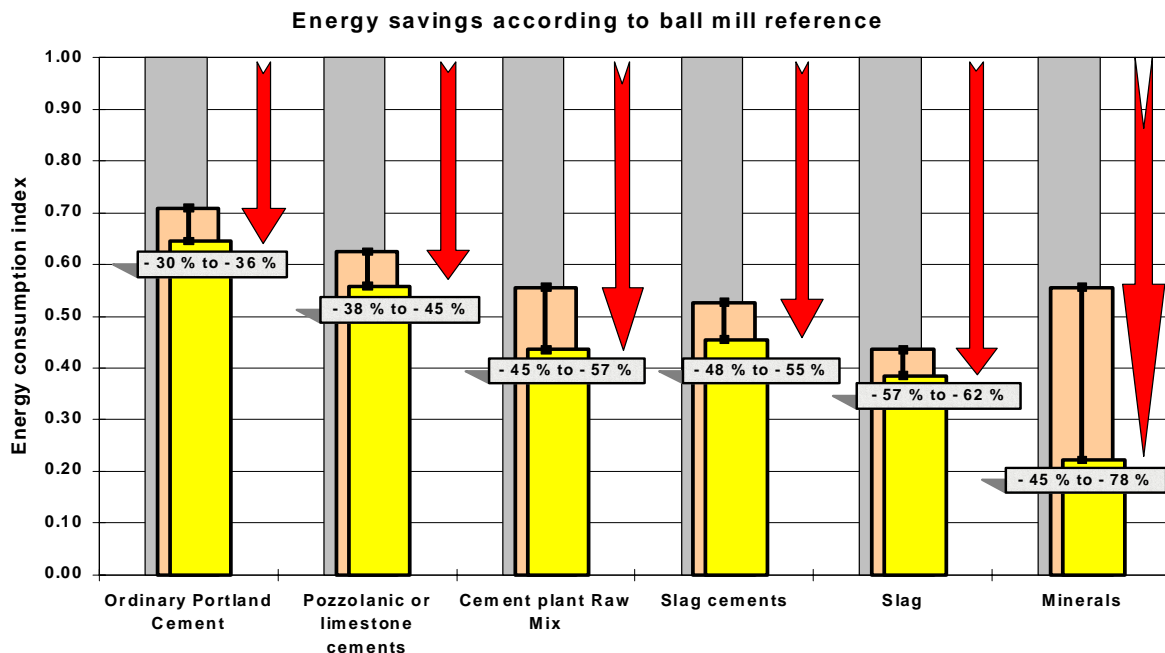

Flexibility: The chart below shows that more than a dozen products are industrially produced in Horomill plants. Each of those products can be made by any of the machines without hardware modification. The Lafarge Karsdorf Plant produces seven different types of products. Change over from one product to another is achieved within minutes without losing intermediate products.

Horomill sites	CEM I	CEM II / A-L	CEM II / A-P	CEM II / B-P	CEM II / B-S	CEM III/A	CEM III/B	CEM V/A	Raw meal	Slag	Limestone	Anhydrite	Dolomite
Trino													
SMA													
Cimentas													
Darica													
Karsdorf													
Tepetzingo													
Cizkovice													
Tepetzingo 1 & 2													
RCC													
Denizli 3 & 4													
Maxit													
Confidential													
Konya													

Quality of products: A comparative follow up made by Cemento Moctezuma in Mexico shows that month after month, compression strength obtained with Horomill cement is identical to that obtained with a conventional ball mill. The Horomill achieves an identical performance with a significantly lower fineness of the cement. That results in an additional energy-savings

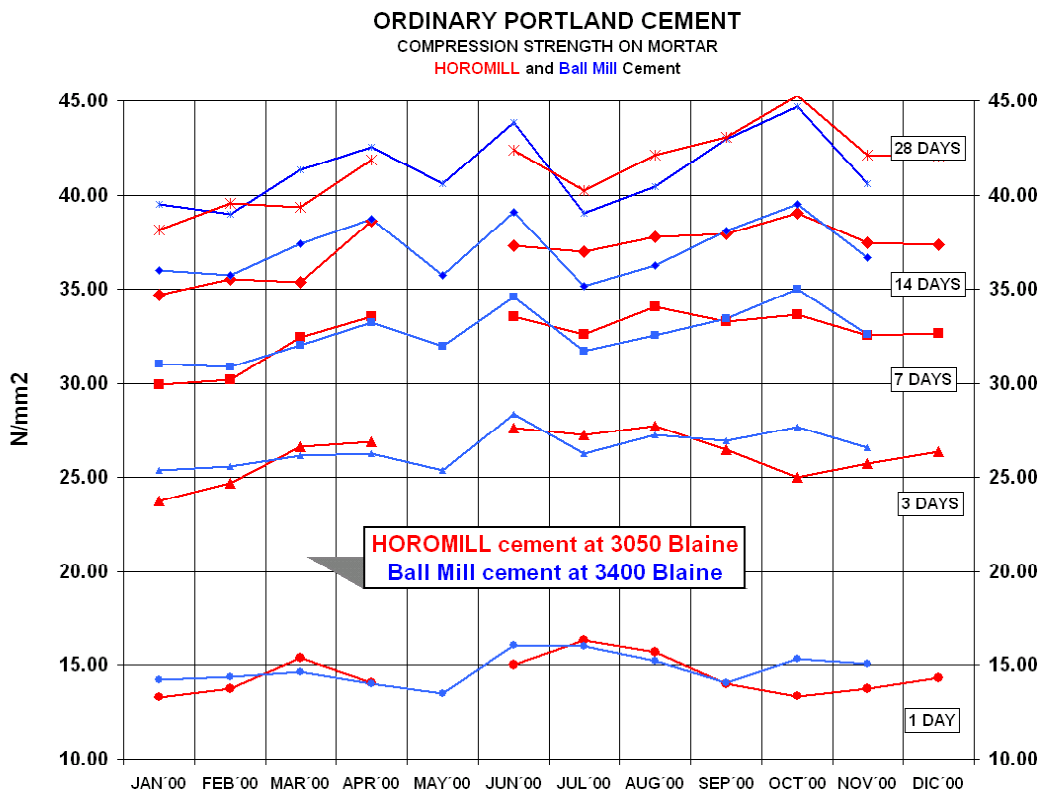

advantage for a given level of final performance, because there is no need to use additional energy for fine grinding.

Financial savings; Currently, the investment cost in a Horomill grinding plant is comparable or lower than for other systems. Further savings should be the result of standardized industrial manufacturing and a corresponding scale effect. Maintenance costs are progressively being optimized but may still offset the benefit of lower electrical consumption.

Automation and ease of operation: The Horomill concept integrates, from the beginning, the possibility of fully automated operation not only for steady operation, start up or shutdown sequences, but also for automatic online switchover from one product to another according to the requirements of the plant production program.

Lessons Learned

Based on the Horomill experience, FCB Ciment concluded that the success of a technical innovation process relies on three stages:

1. **The perception of a demand from the market.** In the case of cement grinding technology, the market demand centered around a continued need for energy savings and disappointment resulting from the difficulties encountered by the first generation of compression grinding machines (the roller press), namely cement quality problems and mechanical weaknesses.
2. **The development of a concept to answer this demand.** The two possibilities were to extrapolate an existing concept by extending its scope of application, adjusting the existing components to the new application or to develop a new concept. Extrapolating existing concepts has several advantages including:
 - Less need for really creative thinking
 - Less technological risk
 - Reduced development costs
 - Acquaintance of stakeholders with the concept - this familiarity reassures future users
 - Immediate benefit on reliability and component costs resulting from the experience accumulated on previous similar machines.

Developing a new concept is more risky as it requires more from:

- Innovators – They need not only to have ideas, but also engineering and testing facilities, as well as strong financial support
- Stakeholders (customers, suppliers, shareholders) and partners - They have to be capable of long term thinking, to be open minded, ready to accept immediate additional development costs and delayed financial returns.

The benefits of a new concept could include:

- A tailor-made solution to meet the demand
- An advantage over competitors for both the machine users and the machine supplier
- Image enhancement for both the cement company and the equipment supplier, when the concept allows better environmental protection and energy savings

3. **The extension of the concept to new applications.** Finally, the success of a technical innovation is achieved not only when the original need is met but when unexpected advantages are realized. Examples of unexpected benefits include:
 - Higher quality and performance of final products manufactured by the machine
 - Extension of the application of the machine to different processes or products,

- Modification of the state of the art in the profession, rendering previous concepts obsolete.

The Horomill has achieved its original goal of improved grinding process performance and energy savings, and has extended its applications to high value added products like minerals with extreme fineness and for bringing new added value to wastes such as slag.. In addition, it has changed the state of the art to some extent by introducing new grinding approaches that would have been hard to imagine through simple extrapolations of old technology. For instance

- The Lafarge Karsdorf plant frequently switches between several products within the same day without stoppage or loss of intermediate product
- In the plant at Tepetzingo Mexico, the raw mill and cement mill are identical machines
- The “Rawcem” Horomill concept introduced for the PR Cement Plant in India with one single Horomill department working part time as a raw mill, part time as a cement mill.

From FCB’s experience and corresponding successes and difficulties, they conclude that the basic ingredients for innovation include:

- New ideas
- A solid engineering capability
- Strong will and perseverance
- Financial strength

Although these conditions are the basic prerequisites, full success can only be achieved by additionally exploiting:

- **The strength of partnerships.** A single company cannot succeed alone. Long-term partners are necessary with both customers and suppliers.
- **A specific organization dedicated to the technology’s success.** The difficulties encountered, especially at the Lafarge plants, were overcome through the mobilization of a dedicated team with customer and supplier engineers working together.
- **Testing facilities at different stages** such as laboratory, prototype, pilot plant, and industrial full-scale machine.

Finally, and especially during the early industrial operation adjustment stage, psychological conditions are very important:

- The people in charge of the machine should be informed of the extra efforts that will be required. Whenever possible, those directly involved with the machine should be volunteers for the challenge, or even better should have participated (positively) in the decision for innovation.
- The cement company hierarchy/management should be committed to the innovation and aware of the direct and indirect benefits that will result from innovation - from savings in their production costs and improved quality in the end product to a better company image both internally and externally.
- The innovation engineers and their managers should be “marathon runners” knowing that the road to success can be much longer and harsher than initially foreseen.

Although new technical concepts are not frequently introduced in the cement industry, the Horomill case study demonstrates that innovation in process design can be successfully implemented. Despite the difficulties encountered, the Horomill technology survived and made positive impacts on energy savings and the resulting environmental impacts, as well as economic benefits for the cement producers. (Table B.2.1 lists the cement plant installations). The Horomill is recognized by many in the cement industry as a value-added innovation.

Although the first two steps in the marketing operation – the identification of market needs and the development of a concept to reply to those needs – have been accomplished, one year ago when this case study was initiated, there was still uncertainty whether the third vital step of making that new concept accepted in the market place, in the context of the market evolving demands, could be reached.

Today it is clear that the Horomill challenge has, on one the hand, triggered a healthful reaction from other technologies (especially vertical mill), and at the same time has demonstrated its own advantages and competitiveness as evidenced by the record new orders.

Table B.2.1 Horomill Plant Installations				
Plant	Model	Country	Production Capacity	Year
Buzzi Trino	2200	Italy	25 tph	1993
Heidelberg/SMA	1600	France	12 tph	1995
Cimentas	3400	Turkey	85 tph	1996
Moctezuma	3800	Mexico	225 tph	1996
Moctezuma	3800	Mexico	105 tph	1997
Lafarge/Darica	3600	Turkey	100 tph	1996
Republic Cement	3600	Philippines	100 tph	1997
Lafarge/Karsdorf	3800	Germany	110 tph	1996
Lafarge/Ciskovice	2800	Czech Republic	60 tph	1996
Galadari	3400	Pakistan	185 tph	2001
Denizli	3400	Turkey	86 tph	1998
Denizli	3400	Turkey	86 tph	1998
Galadari	3400	Pakistan	80 tph	2001
Galadari	3400	Pakistan	80 tph	2001
Maxit	2400	Germany	40 tph	1998
Confidential	2000	Netherlands	10/50 tph	1998
Confidential	2000	France	10/50 tph	2001
Vicat Konya	3800	Turkey	130 tph	1998
Moctezuma	3800	Mexico	225 tph	1999
Buzzi/Barletta	3800	Italy	225 tph	2001
Moctezuma	3800	Mexico	105 tph	2001
PR Cement	3800	India	105/225 tph	2002
Mudanjiang	3800	China	120 tph	2002
Augusta	3800	Italy	100 tph	2002
Cerritos	3800	Mexico	225 tph	2002
Cerritos	3800	Mexico	105 tph	2002
Cerritos	3800	Mexico	105 tph	2002
Hanzhong	3800	China	80 tph	2002
Buzzi/Trino	3800	Italy	105 tph	2002
Confidential	3800	CentralAm	100 tph	2002